

SL Series Slot Sensor

Self-contained opposed-mode sensor pair

SL Series Slot Sensor Features



- An easy-to-use self-contained opposed-mode sensor pair in a rugged U-shaped housing
- Easy and economical to mount
- Molded-in beam guides simplify mounting and beam placement
- 30 mm slot width for a wide variety of sensing applications
- Applications include label detection, hole detection, gear tooth detection, edge guiding and counting
- 10 to 30V dc operation
- Bipolar PNP/NPN outputs
- Visible red beam
- Choose 1 millisecond or 300 microsecond response
- 4-turn potentiometer sensitivity adjustment
- 2 mm effective beam
- Dark or light operate
- Choose integral, unterminated cable or QD models

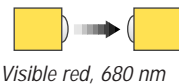
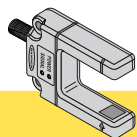

Visible red, 680 nm

SL Series Slot Sensor Models

| Models | Slot Width | Cable* | Supply Voltage | Output Type | Response | Repeatability |
|------------|-----------------|----------------------------|----------------|---|------------------|------------------|
| SL30VB6V | 30 mm (1.2") | 2 m (6.5') 5-wire cable | 10-30V dc | Bipolar NPN (sinking) and PNP (sourcing) | 1 millisecond | 250 microseconds |
| SL30VB6VQ | | 5-Pin Euro-style QD | | | | |
| SL30VB6VY | | 2 m (6.5') 5-wire cable | | | 300 microseconds | 75 microseconds |
| SL30VB6VYQ | | 5-Pin Euro-style QD | | | | |

*NOTES: 1) 9 m (30') cables are available by adding suffix "W/30" to the model number of the cabled version (e.g., **SL30VB6V W/30**).

2) A model with a QD connector requires an accessory mating cable. See page 5.

SL Series Slot Sensor

SL Series Slot Sensor Overview

The SL Series Slot Sensor (sometimes called a “Fork Sensor”) comprises an opposed-mode emitter and its receiver inside a single convenient housing. Opposed-mode sensing is very reliable, and the single self-contained housing provides easy installation, with no sensor alignment required. In addition, the molded-in arrow on the emitter portion of the housing and the slotted design on the receiver portion of the housing show at a glance the position of the beam, simplifying installation placement.

Using the SL Series Slot Sensor

Sensitivity Adjustment

The sensor’s sensitivity is adjusted by turning the 4-turn clutched Sensitivity potentiometer with a small slotted screwdriver. Apply power to the sensor and:

1. Set the potentiometer to minimum sensitivity (fully counter-clockwise) and present the Light condition. If the yellow Signal Condition indicator is ON, that is your Light condition sensitivity position. If not, proceed to step 2.
2. Turn the potentiometer clockwise, just until the yellow Signal Condition indicator comes ON; note its position.

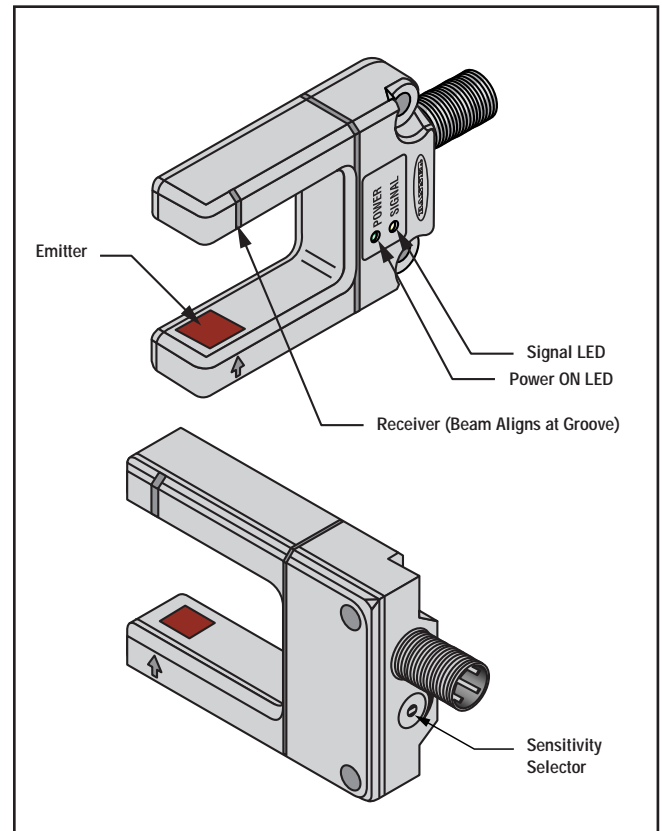

Figure 1. SL Series features

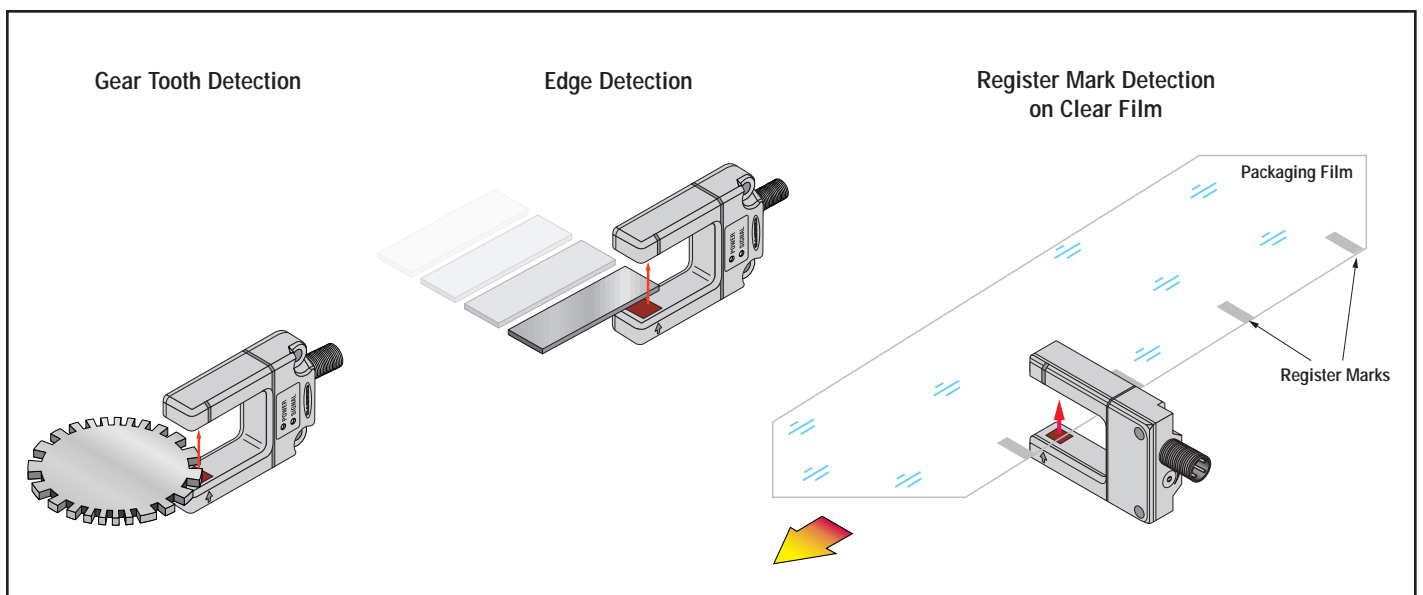

Figure 2. SL Series typical applications

3. Present the Dark condition and turn the potentiometer clockwise, just until the yellow Signal Condition indicator comes ON; note its position.
4. For maximum reliability, the difference between these two positions should be at least one full turn. Set your sensitivity midway between the two positions for best sensing results.

If the object to be sensed is very thin and non-metallic, the sensor may emit too much light energy for the object to completely block the beam. To test this, place the object in the sensing position, and decrease the sensitivity until the yellow LED goes OFF. Remove the object; verify that the indicator comes ON solidly. If this does not occur, investigate other sensing alternatives.

Light/Dark Operate Select

Selecting Light or Dark Operate is a simple procedure: connect the gray wire (see hookups, page 4), to +V (10-30V dc) for Dark Operate, and to dc common (or open) for Light Operate.

LED Indicators

The Slot Sensor features two LED Indicators: Power (green) and Signal (yellow). They indicate the following:

- Green ON steady:** Power ON
- Yellow ON steady:** Sensor sees light
- Yellow flashing:** Excess gain is marginal (1 to 1.5x) in light condition

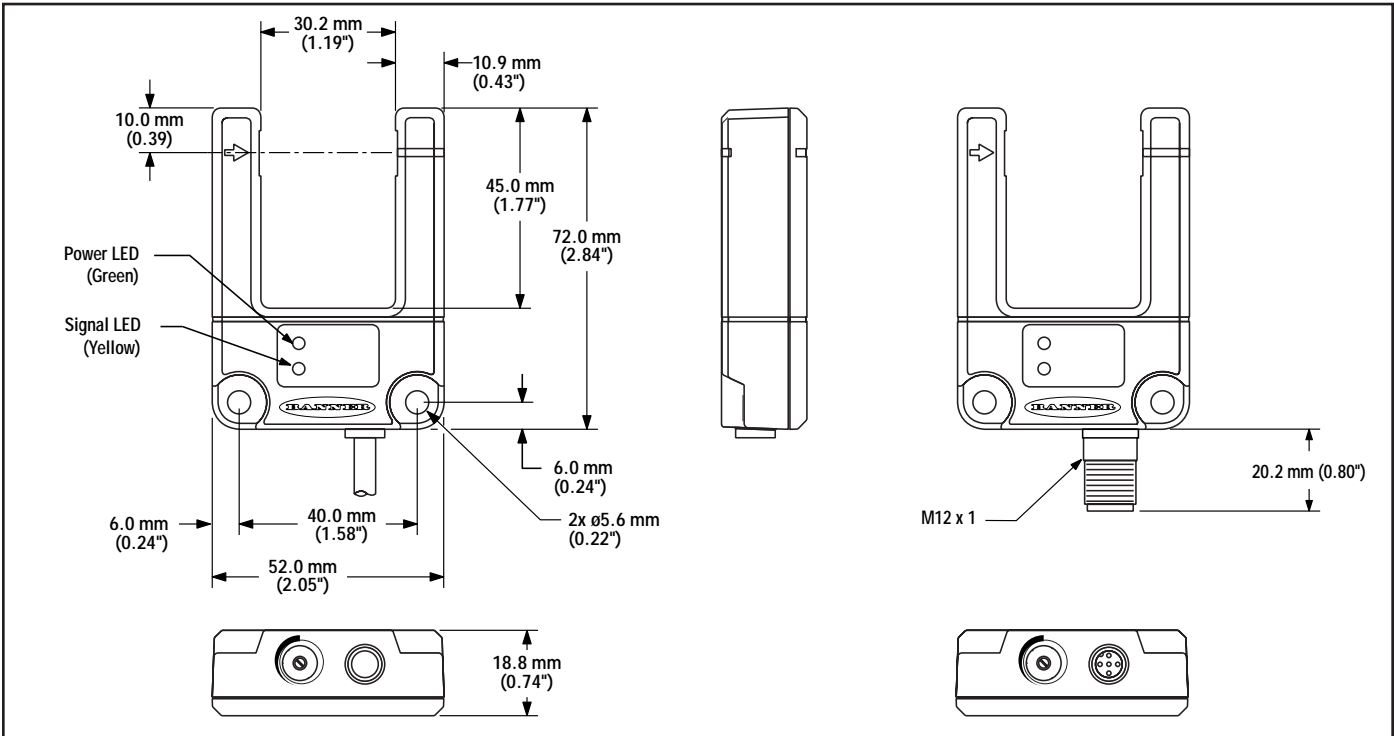

Figure 3. SL Series Slot Sensor dimensions

SL Series Slot Sensor

SL Series Slot Sensor Specifications

| | |
|-----------------------------|--|
| Slot Opening | 30 mm (1.2") wide x 45 mm (1.8") deep overall; beam set in 10 mm (0.4") from outer edge |
| Supply Voltage and Current | 10 to 30V dc, 30 mA |
| Supply Protection Circuitry | Protected against reverse polarity and transient voltages |
| Output Configuration | Bipolar: NPN (current sinking) and PNP (current sourcing) |
| Output Rating | 150mA, each output |
| Output Protection Circuitry | Protected against false pulse on power-up and short-circuit of outputs |
| Output Response Time | 1 millisecond or 300 microseconds, depending on model |
| Repeatability | 250 microseconds or 75 microseconds, depending on model |
| Adjustments | 4-turn clutched potentiometer sensitivity adjustment |
| Indicators | Green: Power ON/OFF indicator Yellow: Signal Condition indicator |
| Construction | Housing: 30% glass-reinforced thermoplastic polyester Lenses: Acrylic |
| Environmental Rating | IP67, NEMA 6 |
| Connections | 2 m (6.5') or 9 m (30') 5-conductor PVC-jacketed attached cable or 5-pin Euro-style quick-disconnect (QD) connector. QD cables are ordered separately; see page 5. |
| Operating Conditions | Operating Temperature: -40° to +70°C (-40° to +158°F) Maximum relative humidity: 90% @ 50°C (non-condensing) |

SL Series Slot Sensor Hookups

Cabled models

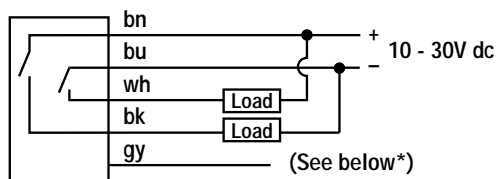

Quick-disconnect models

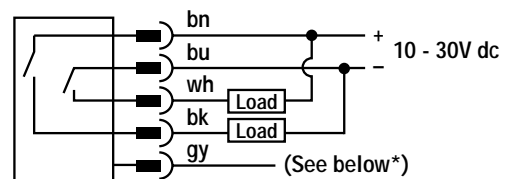

- * For Dark Operate, connect gray wire to + (brown).
For Light Operate, connect gray wire to - (blue) or leave circuit open.

SL Series Slot Sensor

Accessories

Quick-Disconnect Cables

The following cables are available for SL Series Slot Sensor QD models

| Style | Model | Length | Dimensions | Pin-out |
|------------------------------------|---|--------------------------------------|------------|---------|
| 5-pin Euro-style straight | MQDC1-506 MQDC1-515 MQDC1-530 | 2 m (6.5') 5 m (15') 9 m (30') | | |
| 5-pin Euro-style right-angle | MQDC1-506RA MQDC1-515RA MQDC1-530RA | 2 m (6.5') 5 m (15') 9 m (30') | | |

SL Series Slot Sensor



WARRANTY: Banner Engineering Corporation warrants its products to be free from defects for one year. Banner Engineering Corporation will repair or replace, free of charge, any product of its manufacture found to be defective at the time it is returned to the factory during the warranty period. This warranty does not cover damage or liability for the improper application of Banner products. This warranty is in lieu of any other warranty either expressed or implied.