



SLE30 Expert™ Series Teach-Mode Slot Sensor

Self-contained opposed-mode sensor pair with Teach Mode

SLE30 Expert Series Slot Sensor Features



- An easy-to-use, self-contained opposed-mode sensor pair in a rugged U-shaped housing
- Easy push-button programming automatically adjusts sensitivity to optimal setting
- Dynamic TEACH programming option provides on-the-fly convenience and minimizes the effects of web flutter
- Separate TEACH input allows remote programming by an external device, such as a switch or a process controller
- Easy output programming eliminates the need for Light or Dark Operate selection
- Choose fast 500 microsecond or 150 microsecond output response
- 2 mm effective beam
- Visible red beam
- Molded-in beam guides simplify mounting and beam placement
- 30 mm slot width for a wide variety of sensing applications
- Applications include label detection, hole detection, edge guiding and counting
- 10 to 30V dc operation
- Bipolar PNP/NPN outputs
- Choose integral, unterminated cable or QD models

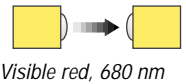

Visible red, 680 nm

SLE30 Expert Series Slot Sensor Models

Models	Slot Width	Cable*	Supply Voltage	Output Type	Response	Repeatability
SLE30B6V	30 mm (1.2")	2 m (6.5') 5-wire cable	10-30V dc	Bipolar NPN (sinking) and PNP (sourcing)	500 microseconds	100 microseconds
SLE30B6VQ		5-Pin Euro-style QD				
SLE30B6VY		2 m (6.5') 5-wire cable			150 microseconds	75 microseconds
SLE30B6VYQ		5-Pin Euro-style QD				

*NOTES: 1) 9 m (30') cables are available by adding suffix "W/30" to the model number of the cabled version (e.g., SLE30B6V W/30).
2) A model with a QD connector requires an accessory mating cable. See page 5.

SLE30 *Expert*™ Series Slot Sensor

SLE30 *Expert* Series Slot Sensor Overview

The SLE30 Series Slot Sensor (sometimes called a “Fork Sensor”) comprises an opposed-mode emitter and its receiver inside a single convenient housing. Opposed-mode sensing is very reliable, and the single self-contained housing provides easy installation, with no sensor alignment required. In addition, the molded-in arrow on the emitter portion of the housing and the slotted design on the receiver portion of the housing show at a glance the position of the beam, simplifying installation placement.

Expert series sensors feature easy-to-use push-button programming, performed in TEACH mode. TEACH-mode programming may be performed using either the push button, or remotely, using a remote switch or process controller. The programming determines whether the sensor outputs will conduct in light or dark conditions, and defines the light and dark conditions for the sensor in each application. The remote switch also may be used to disable the programming push button for security.

The Dynamic TEACH option provides a means for teaching a series of conditions; the SLE30 monitors the sensing events and automatically sets the threshold between light and dark conditions.

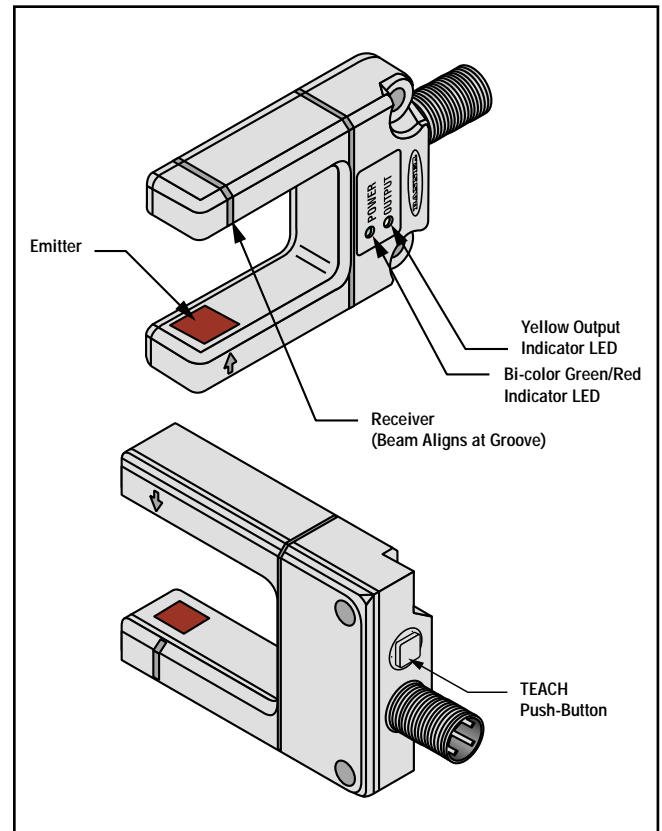

Figure 1. SLE30 *Expert* Series features

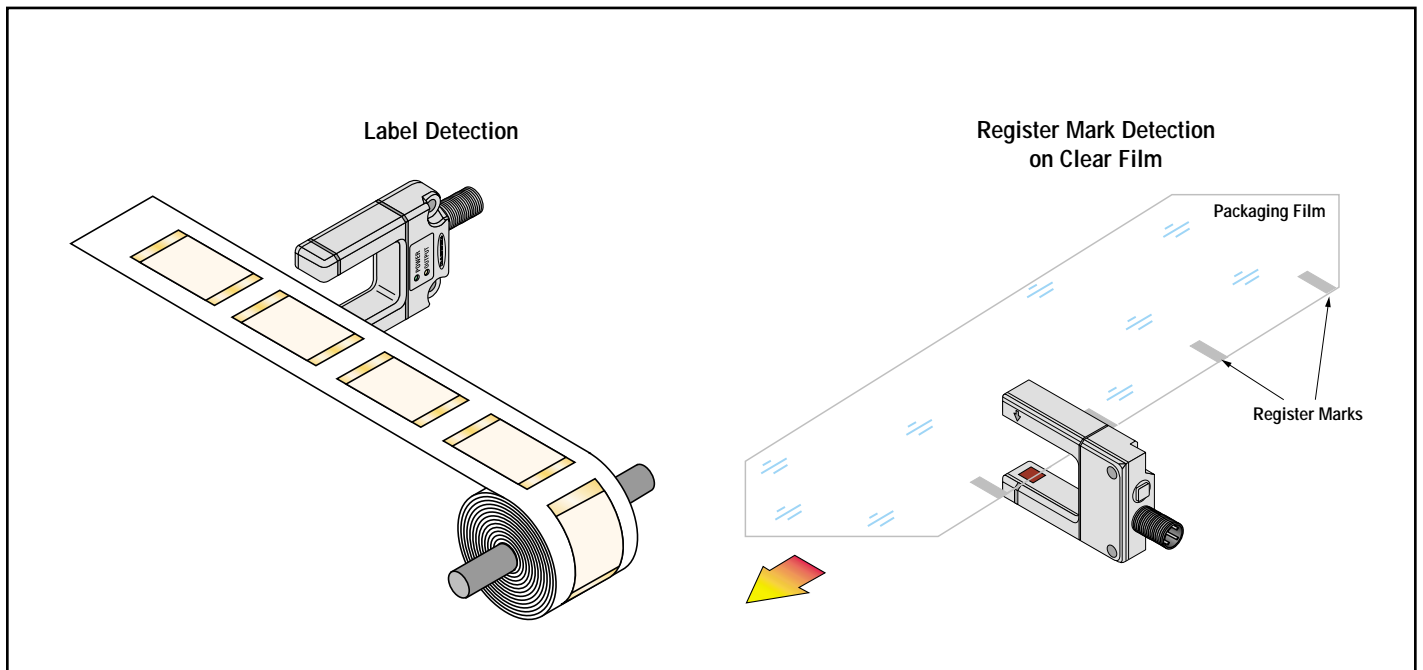

Figure 2. SLE30 *Expert* Series typical applications

Using the SLE30 *Expert* Series Slot Sensor

RUN Mode

Normal operation of the SLE30 *Expert* is called RUN mode. The two LED indicators (bi-color Green/Red and Yellow) operate as follows in RUN Mode:

Green (RUN Mode): ON steady whenever power is applied
Flashes as received light level approaches the switching threshold (stability indicator. The stability indicator signals when maintenance or reprogramming is needed during RUN mode.)

Yellow (Output): ON when the outputs are energized (conducting)
OFF when the outputs are de-energized (not conducting)

If contrast is marginal, the bi-color indicator will flash green (to indicate instability). Reprogramming the sensor, or cleaning the sensor lenses may solve a problem with stability.

TEACH Mode

Programming of the SLE30 *Expert* – setting the sensitivity and selecting output ON and OFF conditions – is performed in TEACH Mode. The SLE30 provides two methods for programming: Static TEACH and Dynamic TEACH. Static TEACH is used in all programming situations to set up the sensor's output ON and output OFF conditions. Sensitivity is then set using either the Static method described below or the Dynamic method on page 4.

Both Static TEACH and Dynamic TEACH may be performed using either the sensor's TEACH push button or the Remote TEACH line (see page 6).

Static TEACH

Determining the Output ON and OFF Conditions

The two sensing conditions may be presented in either order. The condition presented first is the condition for which the outputs will energize (the "Output ON" target).

Setting Sensitivity

Sensitivity is automatically set (and optimized) when teaching the sensor the ON and OFF conditions. When the push button is clicked, the sensor samples each sensing condition and registers it into memory. After the second sensing condition is registered, the SLE30 *Expert* automatically sets the sensitivity to the optimum value for the application, and then returns to RUN mode.

The two LED indicators (bi-color Green/Red and Yellow) operate as follows in TEACH Mode:

Red (TEACH Mode): Lights when the sensor "sees" its modulated light source; pulse rate is proportional to the received light signal strength during TEACH programming

Yellow (Output): ON to indicate TEACH output ON condition
OFF to indicate TEACH output OFF condition

The Signal Strength indicator is Banner's exclusive AID™ (Alignment Indicating Device). Its pulse rate increases as the received light signal strength increases (during programming). This feature simplifies accurate alignment during TEACH mode, and gives a relative indication of sensing contrast between the light and dark conditions.

SLE30 Expert™ Series Slot Sensor

Static TEACH Sequence

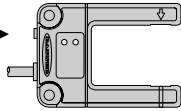
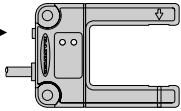
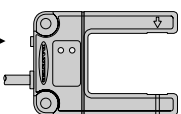
Push Button		Resulting Indicator Status
Press and hold until the bi-color (green/red) indicator begins to flash red, or turns OFF.	Push and Hold →  ≥ 2 Seconds	Yellow: ON Red: Pulses to indicate relative received signal strength.
TEACH Condition #1 (Output ON state) Present the first sensing condition to the sensor and single-click. [†]	Single-Click ↔  Sensing Condition #1 (Output ON State)	Yellow: OFF Red: Pulses to indicate relative received signal strength.
TEACH Condition #2 (Output OFF state) Present the second sensing condition to the sensor and single-click.	Single-Click ↔  Sensing Condition #2 (Output OFF State)	If contrast is acceptable, the sensor returns to RUN mode; otherwise it will return to TEACH Condition #1. Green: ON (or flashes if signal is close to the switching threshold). Yellow: OFF, until the sensing condition changes.

[†]NOTE: The sensor will return to RUN mode if the first TEACH condition is not registered within 90 seconds. TEACH mode may be cancelled before either condition #1 or #2 by holding the push button depressed for ≥ 2 seconds.

A Note About the “Clicks”: Clicks are meant to be pressed firmly, then quickly released. Indicators go ON or OFF after a brief delay; do not wait until LEDs change status before releasing push button. (If push button is pressed for 2 seconds or longer, sensor will automatically return to RUN mode.)

Dynamic TEACH

Dynamic TEACH is a method of setting the sensor's sensitivity while the object to be sensed is in motion. Typical applications are label sensing and small parts detection. In a label application, web flutter may change the amount of light passing through the label and its backing material. Dynamic TEACH will sense this variation and adjust the sensitivity to account for it.

In a small parts detection application, alignment of the object to the sensor's effective beam may make Static TEACH difficult. In this case, Dynamic TEACH will allow you to pass individual or multiple parts through the beam; the sensor then will detect them and set the sensitivity automatically.

Determining the Output ON and OFF Conditions

Dynamic TEACH is used for optimizing the sensor's sensitivity and will not configure the output ON and OFF conditions. A Static TEACH must be used first to change the output ON and OFF conditions, if needed. If the outputs are configured properly for your installation, Dynamic TEACH may be performed as needed without reverting back to Static TEACH.

Setting Sensitivity

Sensitivity is automatically set and optimized when the sensor is taught dynamically. When the push button is depressed and held, the sensor continues to sample events and registers them into memory. Upon release of the button, the sensor chooses the optimum setting for the application and then returns to RUN mode.

SLE30 Expert™ Series Slot Sensor

Dynamic Sampling Rate

When using Dynamic TEACH to sample an application for programming, it is important to consider the speed of the object being sensed. The sensor's sampling rate during this set-up process is much slower than its response time in RUN mode. Once sampling is complete and the sensor returns to RUN mode, sensor response time returns to its original value.

Use the following formula to calculate the target object speed for Dynamic TEACH sampling:

$$\text{Max. speed of object as it passes the sensor} = \frac{\text{Width of object (in inches)} - \text{effective beam (0.07")}}{\text{Dynamic Sampling Rate (0.009 seconds)*}}$$

For example, for an object 0.125" wide:

$$\text{Max. object speed} = \frac{(0.125" - 0.07")}{0.009 \text{ seconds}} = 6.1" / \text{second}$$

Or for an object 2 mm wide:

$$\text{Max. object speed} = \frac{(2 - 1.8 \text{ mm})}{0.009 \text{ seconds}} = 22.2 \text{ mm/second}$$

* NOTE: The Dynamic Sampling Rate for high-speed models ("Y" model suffix) is 8 milliseconds (0.008 seconds)

Dynamic TEACH Sequence

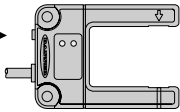
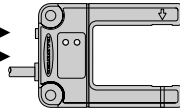
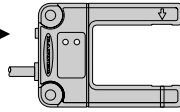
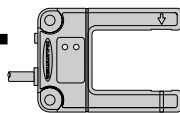
Push Button		Resulting Indicator Status
Press and hold until the bi-color (green/red) indicator begins to flash red, or turns OFF.	Push and Hold →  ≥ 2 Seconds	Yellow: ON Red: Pulses to indicate relative received signal strength.
Initiates Dynamic TEACH Mode	Double-Click ↔ 	Yellow: Pulses at 0.5 Hz. Red: ON
Starts TEACH Process Present the sensing condition while holding the button	Push and Hold →  Sensing Condition	Yellow: ON Solid Red: ON Solid
Ends TEACH Process	Release ← 	If contrast is acceptable, the sensor returns to RUN mode. Otherwise, it will return to Static TEACH mode; double-click to initiate Dynamic TEACH. Green: ON (or flashes if signal is close to the switching threshold). Yellow: ON or OFF, depending on condition

*NOTE: The sensor will return to RUN mode if the first TEACH condition is not registered within 90 seconds. Dynamic TEACH mode may be cancelled by waiting 90 seconds or by cycling sensor power.

SLE30 *Expert*™ Series Slot Sensor

Remote Programming

The gray wire of the SLE30 *Expert* may be connected to a remote switch or process controller to disable or enable the push button (four-pulse) or to program the sensor (single-pulse) through TEACH mode. Remote programming may be done for both the Static and Dynamic TEACH procedures.

A remote programming switch is connected between the gray wire and dc common (see hookup diagrams on page 9). The switch may be either a normally-open contact, or an open-collector NPN transistor with its emitter connected to dc common.

Programming is accomplished using a specified sequence of input pulses. The duration of each pulse is defined as:
 $0.04 \text{ seconds} < T < 0.8 \text{ seconds}$.

The required spacing between adjacent pulses in a sequence (a "four-pulse") is also: $0.04 < T < 0.8 \text{ seconds}$. The timing diagrams (Figure 3, right) illustrate the input requirements.

Locking Out (Disabling) the Push Button

When remote programming is used exclusively, it may be beneficial to disable the push button on the SLE30 *Expert* to increase the security of the settings. The push button can be enabled and/or disabled via the remote line only. If the push button is disabled, TEACH mode cannot be accessed from the push button.

Pulse the Remote TEACH line 4 times (four-pulse) to enable or disable the push button (see timing diagram, Figure 3).

Static TEACH Programming Using the Remote TEACH Line

To pulse the TEACH line, momentarily connect the remote wire to dc common (no press-and-hold procedure is required to enter TEACH mode). This is the equivalent of a "click" when using the sensor TEACH push button.

1. Position the "Output ON" condition and pulse the Remote TEACH line once. The bi-color (green/red) indicator begins to flash red or turn OFF (the AID™ function is indicating signal strength) and the yellow Output indicator will flash briefly and then go OFF.
2. Position the "Output OFF" condition and pulse the Remote TEACH line again. The green indicator will turn ON and the sensor will return to RUN mode with the new settings, if the contrast is adequate. If the contrast is not adequate, the yellow indicator will turn ON and the red AID indicator will remain active, indicating that the sensor is waiting for the first TEACH condition to be retaught. (RUN mode begins a few seconds after the end of TEACH mode.)

NOTE: To exit Static TEACH without updating, hold the Remote TEACH line low (longer than 2 seconds) until the green indicator goes ON, *before teaching the second target*.

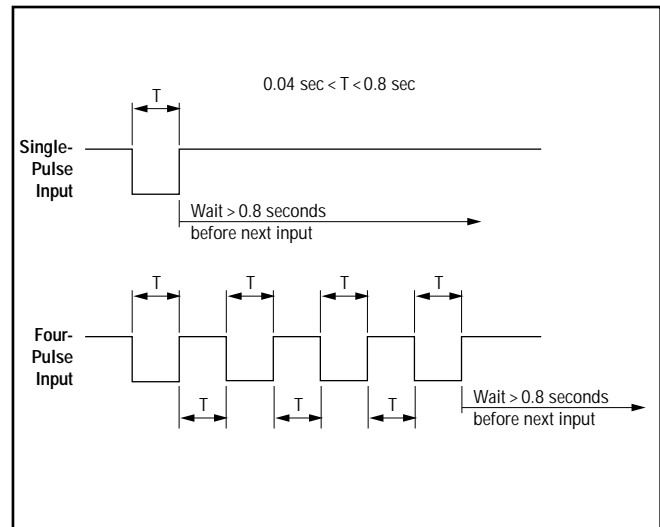

Figure 3. Timing programs for remote programming

Dynamic TEACH Programming Using the Remote TEACH Line

To pulse the TEACH line, momentarily connect the Remote (gray) wire to dc common; no press-and-hold procedure is required to enter TEACH mode. (This is the equivalent of a "click" when using the sensor TEACH push button.)

1. Using the Static TEACH procedure, set up the application's Output ON and OFF conditions. (This step is not necessary if the Output ON and OFF conditions already are configured properly for your application.)
2. Double-pulse the Remote TEACH line (see Figure 3). The sensor is now ready for Dynamic TEACH. The bi-color (green/red) indicator will be ON solid red and the yellow indicator will flash.
3. Hold the Remote line low. Sample sensing events while continuing to hold the Remote line low.
4. Release the Remote line when event sampling is complete. The green indicator will turn ON and the sensor will return to RUN mode with the new settings, if the contrast is adequate.

If the contrast is not adequate, the red indicator will flash at a rate proportional to the received light signal strength and the yellow indicator will be ON solid, indicating that the sensor needs to be retaught. In this case, return to step 2.

NOTE: To exit Dynamic TEACH without updating, wait 90 seconds or cycle sensor power.

Troubleshooting

The SLE30 *Expert's* Power LED may begin to alternate flashing red/green; this indicates a microprocessor memory error. If it occurs, try reteaching the sensor, or try cycling power ON and OFF, then reteaching the sensor. If this does not solve the problem, or if it occurs frequently, replace the sensor.

SLE30 Expert™ Series Slot Sensor

SLE30 Expert Series Slot Sensor Specifications

Supply Voltage and Current	10 to 30V dc (10% maximum ripple) at less than 45 mA, exclusive of load
Supply Protection Circuitry	Protected against reverse polarity and transient voltages
Output Configuration	Bipolar: One current sourcing (PNP) and one current sinking (NPN) open-collector transistor
Output Rating	150mA maximum each output at 25°C, derated to 100 mA at 70°C (derate ≈1 mA per °C) OFF-state leakage current: less than 5µA @ 30V dc ON-state saturation current: less than 1V @ 10 mA; less than 1.5V @ 150 mA
Output Protection Circuitry	Protected against false pulse on power-up and continuous overload or short-circuit of outputs
Output Response Time	Sensors will respond to either a "light" or a "dark" signal of 500 microseconds (or 150 microseconds, depending on model) or longer duration, 1 kHz max. NOTE: 1 second delay on power-up; outputs are non-conducting during this time.
Repeatability	100 microseconds or 75 microseconds, depending on model
Effective Beam	1.8 mm (0.07")
Adjustments	Push-button TEACH mode sensitivity setting (see TEACH mode, page 3); remote TEACH mode input is provided (gray wire)
Indicators	Two LEDs: Yellow and Bi-color Green/Red Green (RUN Mode): ON when power is applied Flashes when received light level approaches the switching threshold Red (TEACH Mode): OFF when no signal is received. Pulses to indicate signal strength (received light level). Rate is proportional to signal strength (the stronger the signal, the faster the pulse rate). This is a function of Banner's patented Alignment Indicating Device (AID™, US patent 4356393). Alternating Red/Green: Flashing Microprocessor memory error (see Troubleshooting, page 7) Yellow (Static TEACH): ON to indicate sensor is ready to learn output ON condition OFF to indicate sensor is ready to learn output OFF condition Yellow (Dynamic TEACH): Pulses at 0.5 Hz when ready to sample ON to indicate Dynamic TEACH sampling OFF to indicate sampling was accepted Yellow (RUN Mode): ON when outputs are conducting
Construction	ABS/polycarbonate housing, acrylic lenses
Environmental Rating	Meets NEMA 6; IEC IP67
Connections	PVC-jacketed 5-conductor 2 m (6.5') or 9 m (30') unterminated cable, or 5-pin Euro-style quick-disconnect (QD) fitting are available. QD cables are ordered separately; see page 10.
Operating Conditions	Temperature: -20° to +70°C (-4° to +158°F) Maximum relative humidity: 90% at 50°C (non-condensing)
Application Notes	The first condition presented during TEACH mode becomes the output ON condition.

SLE30 Expert™ Series Slot Sensor

SLE30 Expert Series Slot Sensor Dimensions

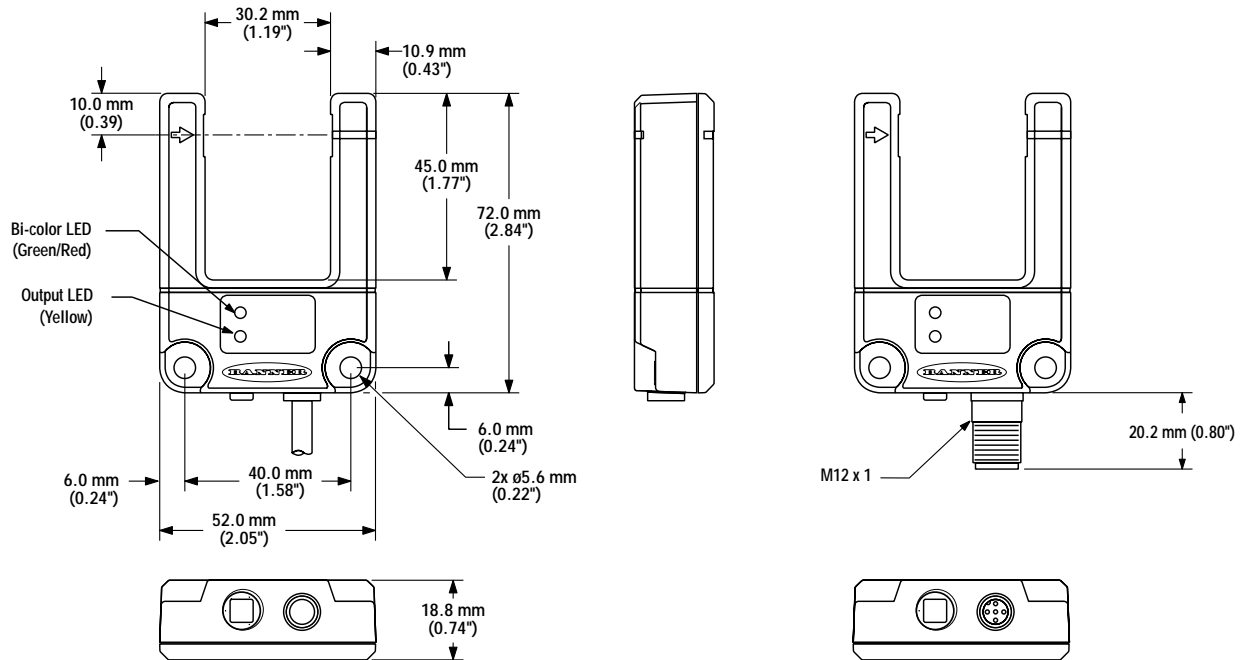

SLE30 Expert Series Slot Sensor Hookups

Cabled Models

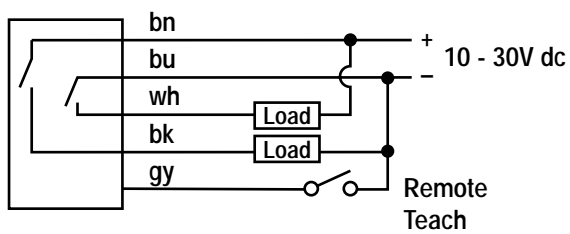

Quick-Disconnect Models

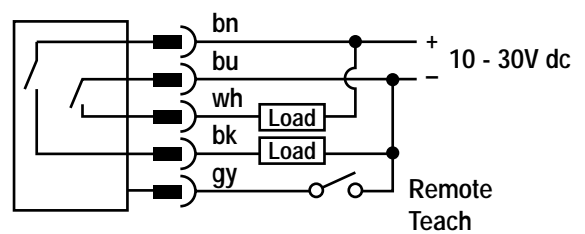

SLE30 Expert™ Series Slot Sensor

Accessories

Quick-Disconnect Cables

The following cables are available for SLE30 Expert Series Slot Sensor QD models

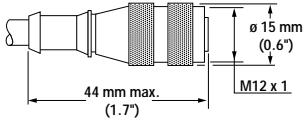
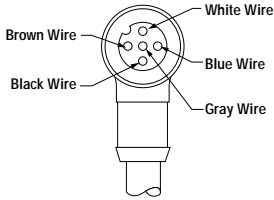
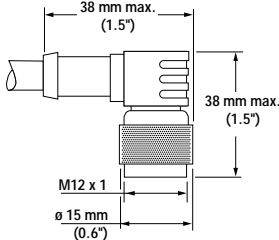
Style	Model	Length	Dimensions	Pin-out
5-pin Euro-style straight	MQDC1-506 MQDC1-515 MQDC1-530	2 m (6.5') 5 m (15') 9 m (30')		
5-pin Euro-style right-angle	MQDC1-506RA MQDC1-515RA MQDC1-530RA	2 m (6.5') 5 m (15') 9 m (30')		

Mounting Brackets

SMBSL

- Angled bracket
- 304 stainless steel; hardware included

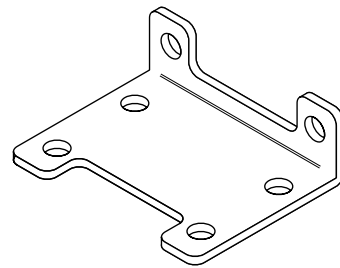
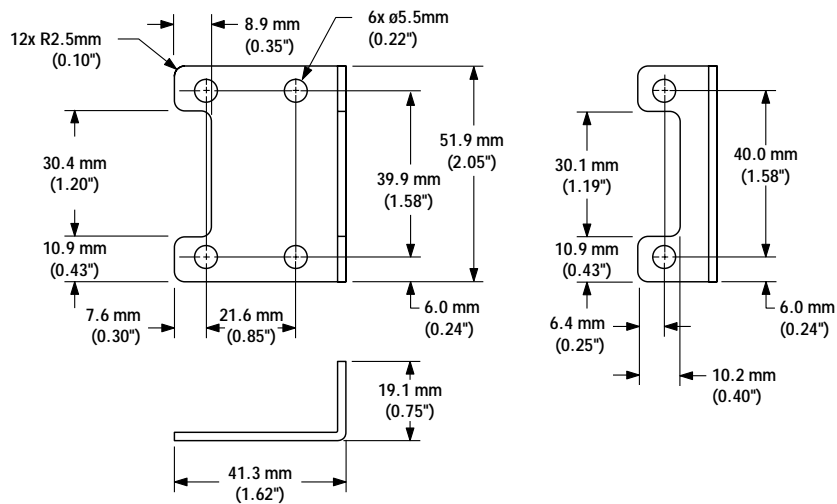

SLE30 *Expert*[™] Series Slot Sensor



WARRANTY: Banner Engineering Corp. warrants its products to be free from defects for one year. Banner Engineering Corp. will repair or replace, free of charge, any product of its manufacture found to be defective at the time it is returned to the factory during the warranty period. This warranty does not cover damage or liability for the improper application of Banner products. This warranty is in lieu of any other warranty either expressed or implied.