

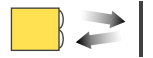

PicoDot™

Convergent Laser Sensors



Visible Red; Class 2 laser; 670 nm

- ### Features
- Compact and lightweight; ideal for use on robotic end effectors
  - Precise 0.25 mm (0.01 in) beam width at the convergent focus
  - Provides the ultimate sensing solution for semiconductor wafer mapping
  - Excels at sensing small parts and profiles and uses fixed-field technology to ignore objects beyond the maximum sensing distance
  - Fast, 0.2 millisecond sensing response for high-speed sensing or counting
  - 10 to 30V dc operation; choice of NPN (sinking) or PNP (sourcing) complementary solid state output
  - Choose models with 2 meter (6.5 foot) or 9 meter (30 foot) integral cable, or with euro-style pigtail quick disconnect QD connector

Convergent Laser Mode						
Models	Focus	Cable	Supply Voltage	Output Type	Excess Gain	Beam Width
					Performance based on 90% reflectance white test card	
PD45VN6C100 PD45VN6C100Q	102 mm (4.0 in)	2 m (6.5 ft) 5-pin Euro QD 150 mm (6 in) pigtail	10-30V dc	NPN		
PD45VP6C100 PD45VP6C100Q		2 m (6.5 ft) 5-pin Euro QD 150 mm (6 in) pigtail		PNP		
PD45VN6C200 PD45VN6C200Q	203 mm (8.0 in)	2 m (6.5 ft) 5-pin Euro QD 150 mm (6 in) pigtail	10-30V dc	NPN		
PD45VP6C200 PD45VP6C200Q		2 m (6.5 ft) 5-pin Euro QD 150 mm (6 in) pigtail		PNP		

For PicoDot Sensors:

- i) 9 m (30 ft) cables are available by adding suffix "W/30" to the model number of any cabled sensor (e.g. - PD45VN6C100 W/30)
- ii) A model with a QD connector requires an optional mating cable

Product Specifications	
Sensing Beam	Visible red Class 2 laser, 670 nm
Sensing Range	<b>C100 models:</b> 25 to 115 millimeters (1 to 4.5 inches); focus at 102 ±5 millimeters (4.0 ± 0.2 inches) <b>C200 models:</b> 25 to 216 millimeters (1 to 8.5 inches); focus at 203 ±5 millimeters (8.0 ± 0.2 inches)
Supply Voltage	10 to 30V dc (10% maximum ripple) at less than 20 milliamps, exclusive of load
Supply Protection Circuitry	Protected against reverse polarity, over voltage, and transient voltages
Output Configuration	SPDT (complementary) solid-state switch; Choose NPN (current sinking) or PNP (current sourcing) models Light operate: Normally-open output conducts when the sensor sees its own modulated light Dark operate: Normally-closed output conducts when the sensor sees dark
Output Rating	150 mA maximum (each output) <b>Off-state leakage current</b> <1 microamp at 30V dc; <b>On-state saturation voltage</b> <0.3V at 10 mA dc; <0.8V at 150 mA dc
Output Protection	Protected against continuous overload or short-circuit of outputs; Overload trip point ≥ 220 milliamps
Output Response Time	0.2 milliseconds (200 microseconds) "on" and "off"
Repeatability	50 microseconds
Adjustments	12-turn slotted brass GAIN (sensitivity) adjustment potentiometer (clutched at both ends of travel)
Extinguishing Wire	Gray wire held "low" for laser operation; "high" to turn laser off; Low = ≤1.0V dc; High = ≥+V-4.0V dc (<30V dc) or disconnect wire
Indicators	Two LEDs: Green and Yellow GREEN <b>glowing steadily</b> = power to sensor is "on" YELLOW <b>glowing steadily</b> = light is sensed; normally open output is conducting GREEN <b>Blinking</b> = power overloaded YELLOW <b>Blinking</b> = marginal return signal
Construction	Housings are Cyclocac® KJB heat-resistant ABS, UL94-VO rated; acrylic lens cover
Environmental Rating	NEMA 3; IEC IP54
Connections	2 m (6-1/2 ft) or 9 m (30 ft) attached cable, or 5-pin euro-style 150 mm (6 in) pigtail quick-disconnect fitting; mating cables for QD models are ordered separately
Operating Temperature	-10° to +45°C (+14° to 113°F); Maximum relative humidity 90% at 50°C (non-condensing)
Weight	Sensor only: 22g (0.8 oz) Sensor plus 2 m cable 62g (2.2 oz)
Application Notes	False pulse may occur <1 second after power-up
Certifications	

## Class 2 Safety Notes

Low-power lasers are by definition incapable of causing eye injury within the duration of the blink, or aversion response of 0.25 seconds. They must also emit only visible wavelengths (400 - 700 nm). Therefore, an ocular hazard can only exist if an individual overcomes their natural aversion to bright light and stares directly into the laser beam. The product requirements for these lasers are to have a [hazard] label and to have an indicator light to indicate laser emission.

The two operational safety rules are:

- Do not permit a person to stare at the laser from within the beam
- Do not point the laser at a person's eye at close range

### Beam Paths:

The beam emitted by a Class 2 laser product should be terminated at the end of its useful path. Open laser beam paths should be located above or below eye level where practical.



**LASER LIGHT**  
DO NOT STARE INTO BEAM  
CLASS 2 LASER PRODUCT

Avoid exposure - laser light emitted from this aperture

PEAK POWER 2 mW  
20KHz 10% DUTY CYCLE  
660 - 680 nm  
COMPLIES TO 21 CFR PART  
1040.10 AND EN60825-1:1994

## Dimension Information

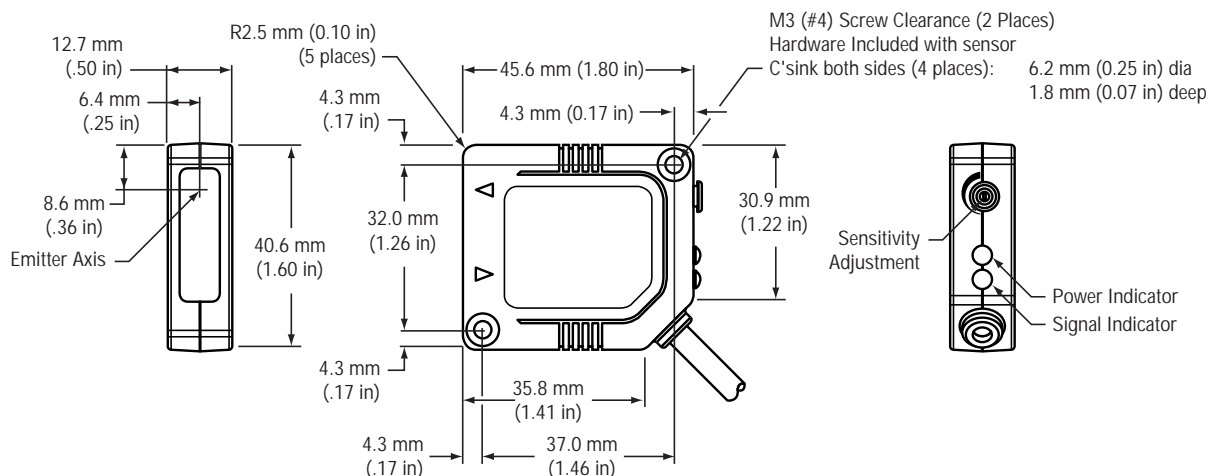

## Hookup Information

### NPN Cabled Hookup

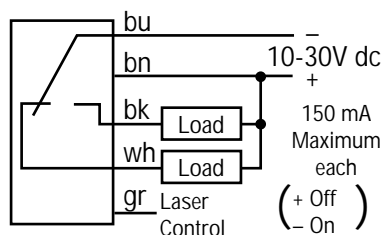

### PNP Cabled Hookup

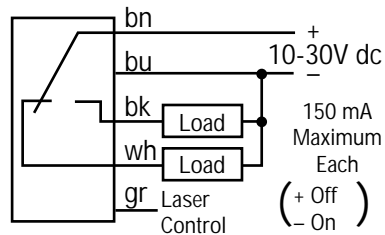

### NPN QD Hookup

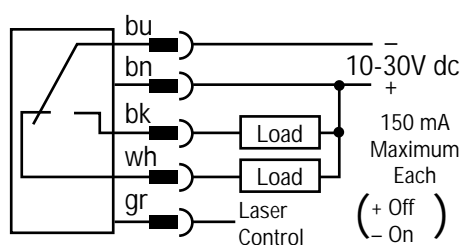

### PNP QD Hookup

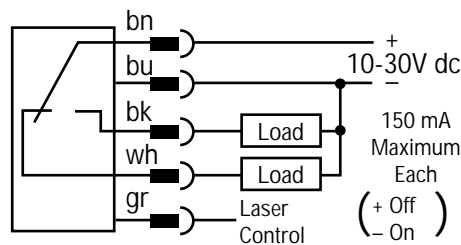

## Quick Disconnect (QD) Option

PicoDot sensors are sold with either a 2 meter (6.5 ft) attached PVC-covered cable, or with a 5-pin euro-style QD cable fitting.

PicoDot QD sensors are identified by the letter "Q" in their model number suffix. Mating cables for QD PicoDot sensors are model MQDC1-5xx (straight connector) or MQDC1-5xxRA (right-angled connector). Cables are supplied in two lengths, 5 meters (15 ft) or 10 meters (30 ft). For more information on QD cables see page 6.

## 5-Pin Euro-Style Pin-out (Mating Cable Connector Shown)

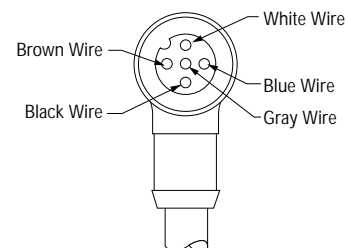

## Mounting Bracket Information

### SMB46L

Material: 303 Stainless Steel

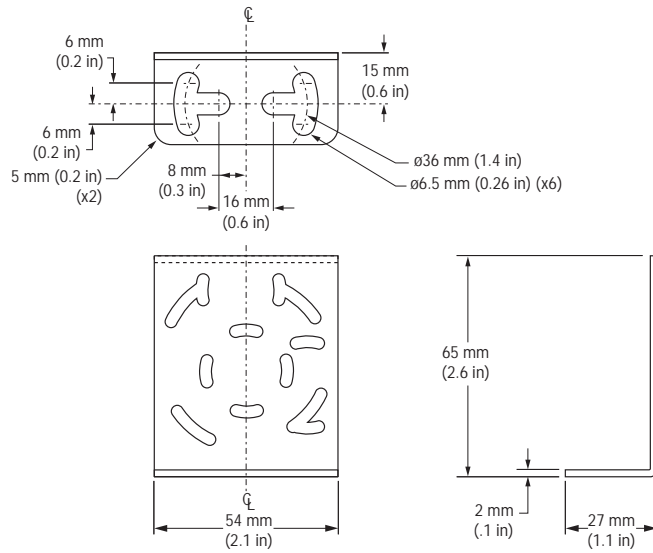

### SMB46S

Material: 303 Stainless Steel

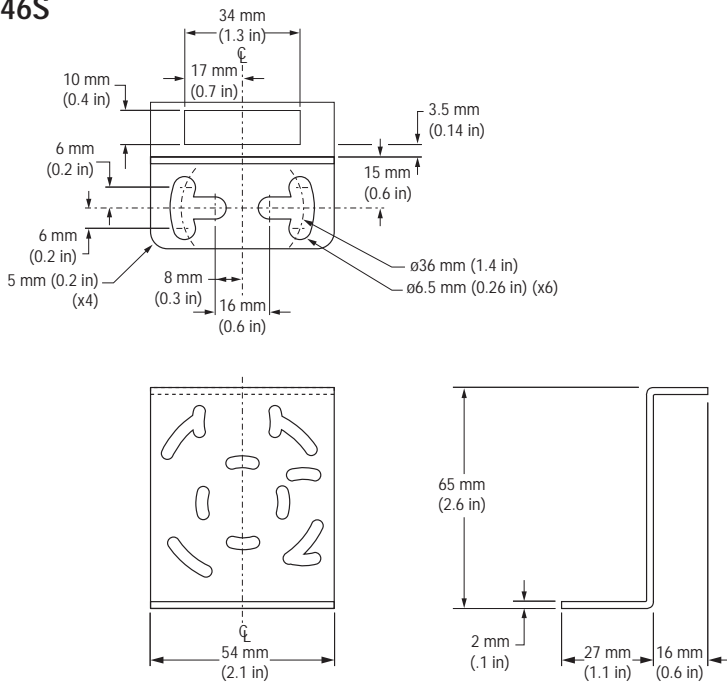

## Mounting Bracket Information

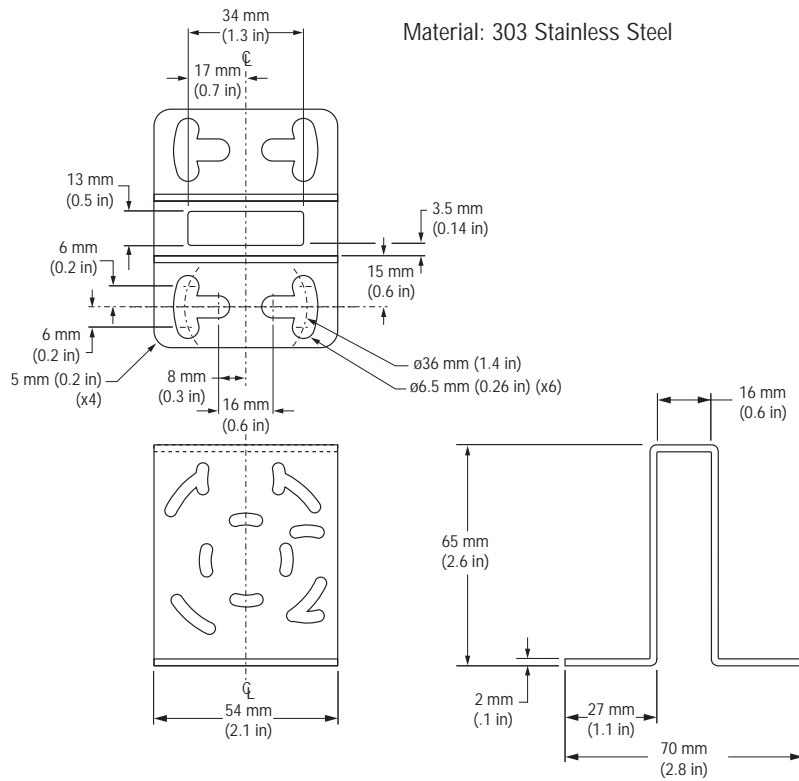

**SMB46U**

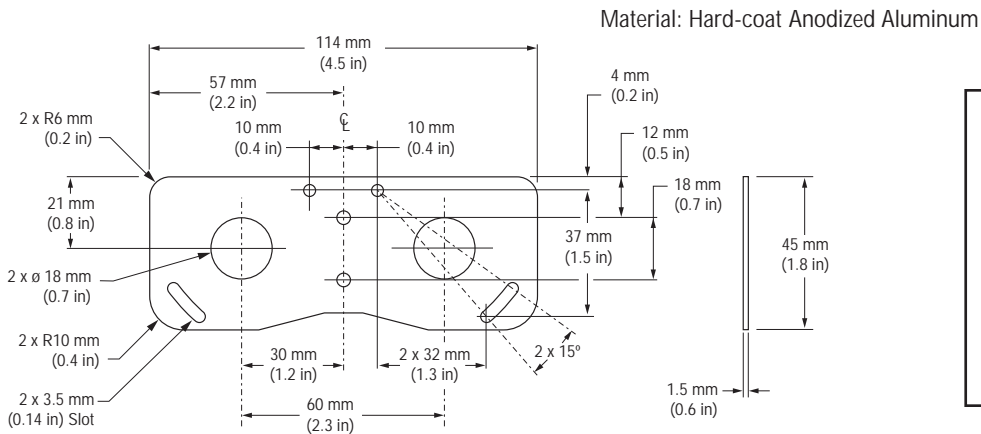

**SMB46DF**



# PicoDot™ Quick Disconnect Cables

## Euro-Style Quick Disconnect Cables

**Cable:** PVC jacket, polyurethane connector body, chrome-plated brass coupling nut  
**Conductors:** 22 or 20 AWG high-flex stranded, PVC insulation, gold-plated contacts  
**Temperature:** -40 to +90°C (-40 to +194°F)  
**Voltage Rating:** 250V ac/300V dc

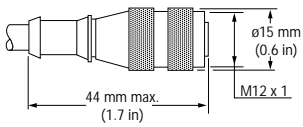
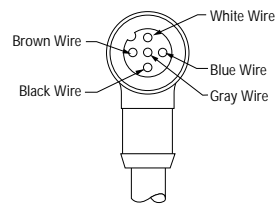
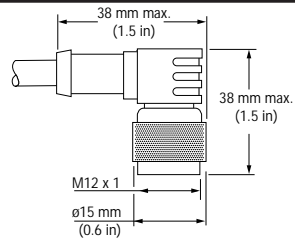
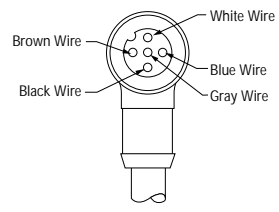
Style	Model	Length	Used with:	Pin-out
5-Pin Straight	MQDC1-506 MQDC1-515 MQDC1-530	2 m (6.5 ft) 5 m (15 ft) 10 m (30 ft)		
5-Pin Right-angle	MQDC1-506RA MQDC1-515RA MQDC1-530RA	2 m (6.5 ft) 5 m (15 ft) 10 m (30 ft)		



### CAUTION

Use of controls or adjustments or performance of procedures other than those specified herein may result in hazardous radiation exposure; per EN 60825. Do **NOT** attempt to disassemble this sensor for repair. A defective unit must be returned to the manufacturer.

**WARRANTY:** Banner Engineering Corporation warrants its products to be free from defects for one year. Banner Engineering Corporation will repair or replace, free of charge, any product of its manufacture found to be defective at the time it is returned to the factory during the warranty period. This warranty does not cover damage or liability for the improper application of Banner products. This warranty is in lieu of any other warranty either expressed or implied.



**WARNING** These photoelectric presence sensors do **NOT** include the self-checking redundant circuitry necessary to allow their use in personnel safety applications. A sensor failure or malfunction can result in either an energized or a de-energized sensor output condition.

Never use these products as sensing devices for personnel protection. Their use as a safety device may create an unsafe condition which could lead to serious injury or death.

Only MINI-SCREEN™, MULTI-SCREEN™, MACHINE-GUARD and PERIMETER-GUARD Systems, and other systems so designated, are designed to meet OSHA and ANSI machine safety standards for point-of-operation guarding devices. No other Banner sensors or controls are designed to meet these standards, and they must **NOT** be used as sensing devices for personnel protection.