



D11 Expert Series with Visible Green or Blue LED Light Source

Low cost teach-mode sensors for use with plastic fiber optics



Features

- Visible green or blue LED light source for use in color mark sensing and other low-contrast sensing applications
- Low cost, 10 to 30V dc self-contained **TEACH** mode sensors for use with all Banner plastic fiber optics
- Compact 11 mm-wide housing designed for DIN rail mounting; can also be mounted to any surface using the supplied mounting bracket
- Easy push button **TEACH** mode programming automatically adjusts sensitivity to optimal setting
- Designed for high-performance, even in low-contrast sensing applications
- Fast, 200 microsecond (0.2 millisecond) output response; a 40 millisecond output pulse stretcher may be programmed, when needed
- Choose models with NPN (sinking) or PNP (sourcing) output
- Output may be programmed for either light or dark operate
- Separate input for remote programming by external switch, process controller, etc.
- LED status indications for power "On", output state, received signal strength, and sensing contrast
- Choose models with integral 2 m (6.5 ft) cable or pico-style quick disconnect (QD) connector; 9 m (30 ft) cables are also available

¹ U.S. Patent #5087838

D11 Series

Models	Range	Cable	Supply Voltage	Output Type	Range Specifications
					Diffuse mode performance based on 90% reflectance white test card
Visible Green D11EN6FPG D11EN6FPGQ	Range varies by sensing mode and fiber optics used	2 m (6.5 ft) 4-pin Pico QD	10-30V dc	Complementary NPN (sinking)	PIT46U fibers, opposed mode: 50 mm (2.0 in)* PIT66U fibers, opposed mode: 80 mm (3.1 in) PBT46U fiber, diffuse mode: 17 mm (0.7 in) PBT66U fiber, diffuse mode: 25 mm (1.0 in) * Opposed mode range may be extended using optional lenses (see Banner Products Catalog for available lenses).
D11EP6FPG D11EP6FPGQ		2 m (6.5 ft) 4-pin Pico QD		Complementary PNP (sourcing)	
Visible Blue D11EN6FPB D11EN6FPBQ		2 m (6.5 ft) 4-pin Pico QD		Complementary NPN (sinking)	
D11EP6FPB D11EP6FPBQ		2 m (6.5 ft) 4-pin Pico QD		Complementary PNP (sourcing)	

Notes:

- 1) 9 m (30 ft) cables are available by adding suffix "**W/30**" to the model number of any cabled sensor (e.g. **D11EN6FPG W/30**).
- 2) A model with a QD connector requires an optional mating cable (see page 6).

D11E Series Sensors with Visible Green or Blue LED Light Source

RUN Mode

Normal operation of the D11 Expert is called the "RUN mode". The LED indicators operate in the **RUN** mode, as follows:

Indicator	LED Color	Function
Power "ON"	Green	1) On steadily whenever power is applied 2) Flashes at approximately 4Hz to indicate that the output is overloaded
Output Indicator	Yellow	Follows the action of the output: On when the output is energized Off when the output is de-energized
Signal Strength	Red	Lights whenever the sensor "sees" its modulated light source and pulses at a rate which is proportional to the received light signal strength

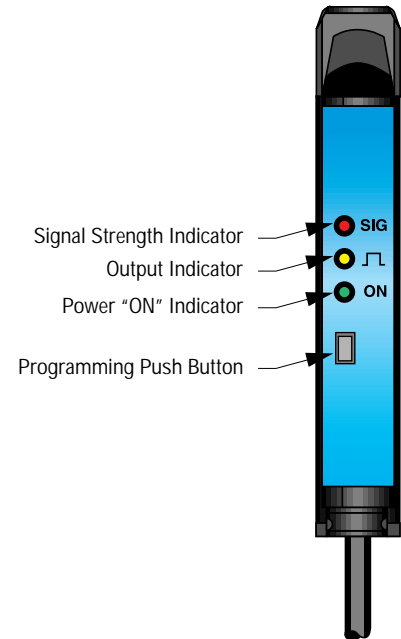

The Signal Strength indicator is Banner's exclusive AID™ (Alignment Indicating Device, U.S. Patent #4356393). This feature makes alignment during the **TEACH** mode easy and accurate and provides a means of signaling when maintenance is needed whenever in the **RUN** mode. Whenever the pulse rate is slow, the fiber sensing ends should be cleaned and/or the alignment checked.

TEACH Mode

Sensitivity is automatically set (and optimized) by "teaching" the sensor the light and dark conditions. This is accomplished in the **TEACH** mode. The **TEACH** mode simply requires that each of the two sensing conditions be presented to the fiber optics. When the push button is clicked, the sensor samples the sensing condition and registers it into memory. After the second sensing condition is registered, the D11E automatically sets the sensitivity to the optimum value for the application, and then returns to the **RUN** mode.

Note: There is a period of a few seconds at the end of the TEACH mode before the RUN mode begins.

Light or Dark Operate Selection

The two sensing conditions may be presented in either order: the light condition, first, and then the dark condition, or vice versa. The condition which is presented first sets the condition for which the output will energize. In other words, the output will be light operated if the light condition is **TEACH** condition #1, or the output will be dark operated if the dark condition is **TEACH** condition #1.

D11E Series Sensors with Visible Green or Blue LED Light Source

Contrast Indication

When the push button is clicked to teach the second sensing condition, the three LED indicators flash simultaneously to indicate relative sensing contrast. Contrast is the difference in light level between the two sensing conditions. Higher contrast allows higher sensitivity level, and resulting higher excess gain. A high contrast level is directly related to sensing reliability, and forgiveness to subtle changes in sensing conditions. The display of contrast at the end of the **TEACH** mode is as follows:

Number of Flashes at end of TEACH mode	Relative Contrast
1	Unacceptable
2	Low
3	Moderate
4	High

Note: If the relative contrast level is unacceptable (1 flash), the program will return to TEACH Condition #1.

TEACH MODE Programming

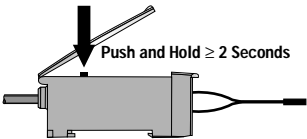
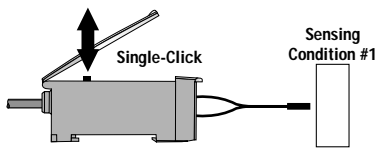
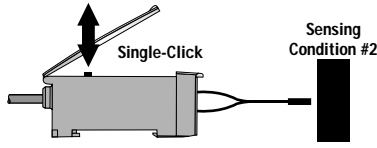
Push Button	Indicator Status
Push and hold for ≥ 2 seconds 	Green: Flashes at 1Hz Yellow: Off Red: Pulses to indicate relative received signal strength
TEACH Condition #1 Present the first sensing condition to the sensor and single click ¹ <i>Note: this will be the condition corresponding to the "on" state of the sensor output</i> 	Green: Flashes at 2Hz Yellow: Off Red: Pulses to indicate relative received signal strength
TEACH Condition #2 Present the second sensing condition to the sensor and single click <i>Note: this will be the condition corresponding to the "off" state of the sensor output</i> 	Green, Yellow, and Red indicators flash simultaneously one to four times to indicate relative sensing contrast (see chart, above). After a few seconds, the sensor returns to the RUN mode

¹NOTE: The sensor will return to **RUN** mode if the first **TEACH** condition is not registered within 20 seconds. **TEACH** mode may be cancelled before either condition #1 or #2 by holding the push button depressed for 2 seconds.

Maximum Sensitivity Setting

D11E sensors are factory-programmed for maximum sensitivity. This default setting may be easily recalled by holding the push button for two or more seconds to enter the **TEACH** mode, and then clicking the push button four times in a row.

NOTE: the default program includes light operate output and pulse stretcher "off".

D11E Series Sensors with Visible Green or Blue LED Light Source

Output Pulse Stretcher

A 40 millisecond pulse stretcher (OFF-delay) may be enabled for applications where a very short sensing event might be missed due to the response of the load or input connected to the sensor output. The pulse stretcher is turned "on" or "off" using the following procedure:

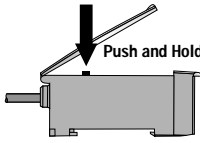
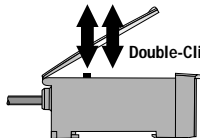
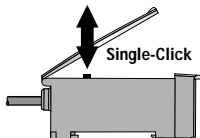
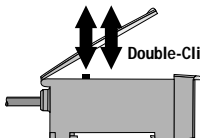
Push Button		Indicator Status	
Push and hold for ≥ 2 seconds	 <p>Push and Hold ≥ 2 Seconds</p>	Green: Flashes at 1Hz Yellow: Off Red: Pulses to indicate relative received signal strength	
PULSE STRETCHER Double-click to display status Single-click to toggle pulse stretcher "on" or "off"	 <p>Double-Click</p>  <p>Single-Click</p>	pulse stretcher "ON": Green: Off Yellow: Off Red: On steadily	pulse stretcher "OFF": Green: Off Yellow: Off Red: Double-Flash
Double-click to save configuration and return to RUN mode	 <p>Double-Click</p>	See page 2	

D11E Series Sensors with Visible Green or Blue LED Light Source

DC Product Specifications	
Required Fiber Optic Cable	PI or PB Series plastic fibers
Sensing Beam	Visible green, 525 nm; Visible blue, 470 nm
Supply Voltage and Current	10 to 30V dc (10% maximum ripple) at less than 45 mA, exclusive of load
Supply Protection Circuitry	Protected against reverse polarity and transient voltages
Output Configuration	One (SPST) NPN (sinking) or PNP (sourcing) open-collector transistor, depending on model; Programmable for light or dark operate
Output Rating	150 mA maximum; Off-state leakage current: <5 microamps at 30V dc; On-state saturation voltage: <1V at 10 mA dc; <1.5V at 150 mA dc
Output Protection Circuitry	Protected against false pulse on power-up and continuous overload or short-circuit
Output Response Time	200 microseconds (0.2 milliseconds) "on" and "off" (40 milliseconds "off" when pulse stretcher is programmed) NOTE: 100 millisecond delay on power-up: output is non-conducting during this time
Output Timing Functions	ON/OFF (no delay) or fixed 40 millisecond OFF-Delay pulse stretcher; selected by push button
Repeatability	65 microseconds
Adjustments	Push button teach mode sensitivity setting (see "TEACH mode" information); Remote teach mode input is provided
Indicators	Three LEDs: Green, Yellow and Red Green LED lights for dc power "ON" and flashes when ready to register sensing condition during TEACH mode; 1 Hz when waiting to learn first sensing condition; 2 Hz when waiting to learn second sensing condition, 4 Hz when output is overloaded Yellow LED lights for output "ON" (conducting) Red LED is Banner's patented Alignment Indicating Device (AID™, U.S. patent #4356393) which lights whenever the sensor "sees" a light condition and superimposes a pulse rate which is proportional to the strength of the received light signal (the stronger the signal, the faster the pulse rate)
Construction	Black ABS (Cyclac® KJB) flame retardent housing with acrylic cover; Stainless steel M3 x 0.5 hardware for use with ABS (Cyclac® KJB) mounting bracket (supplied)
Environmental Rating	IEC IP54; NEMA 2
Connections	2 m (6-1/2 ft) or 9 m (30 ft) attached cable, or 4-pin pico-style quick-disconnect fitting; Cables for QD models are purchased separately
Operating Temperature	-10° to +55°C (-14° to +131°F); Maximum relative humidity 90% at 50°C (non-condensing)
Certifications	

Cyclac® is a registered trademark of General Electric Company.



WARNING These photoelectric presence sensors do NOT include the self-checking redundant circuitry necessary to allow their use in personnel safety applications. A sensor failure or malfunction can result in either an energized or a de-energized sensor output condition.

Never use these products as sensing devices for personnel protection. Their use as a safety device may create an unsafe condition which could lead to serious injury or death.

Only MINI-SCREEN™, MULTI-SCREEN™, MACHINE-GUARD and PERIMETER-GUARD Systems, and other systems so designated, are designed to meet OSHA and ANSI machine safety standards for point-of-operation guarding devices. No other Banner sensors or controls are designed to meet these standards, and they must NOT be used as sensing devices for personnel protection.

D11E Series Sensors with Visible Green or Blue LED Light Source

Hookup Diagrams

Sensors with NPN (Sinking) Outputs

Cabled Hookup

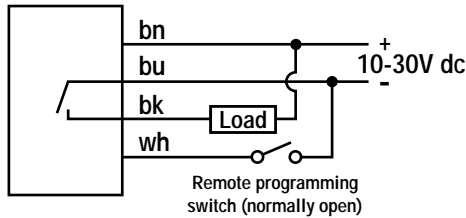

Sensors with PNP (Sourcing) Outputs

Cabled Hookup

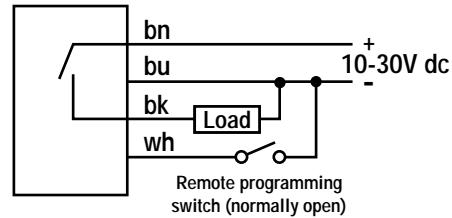

Quick disconnect Hookup

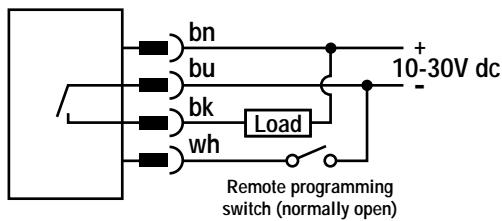

Quick disconnect Hookup

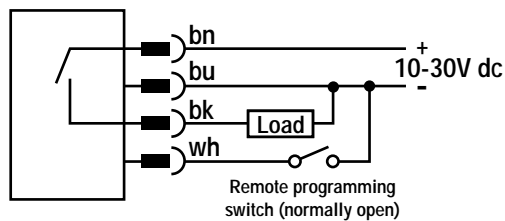

Quick Disconnect (QD) Cables

The following is the selection of cables available for D11 QD models

Style	Model	Length	For use with	Dimensions	Pinout
4-pin Pico Style straight	PKG4-2	2 m (6.5 ft)	All D11 sensors with quick-disconnect fitting		
4-pin Pico Style right-angle	PKW4-2	2 m (6.5 ft)			

D11E Series Sensors with Visible Green or Blue LED Light Source

Dimensions

Cabled models

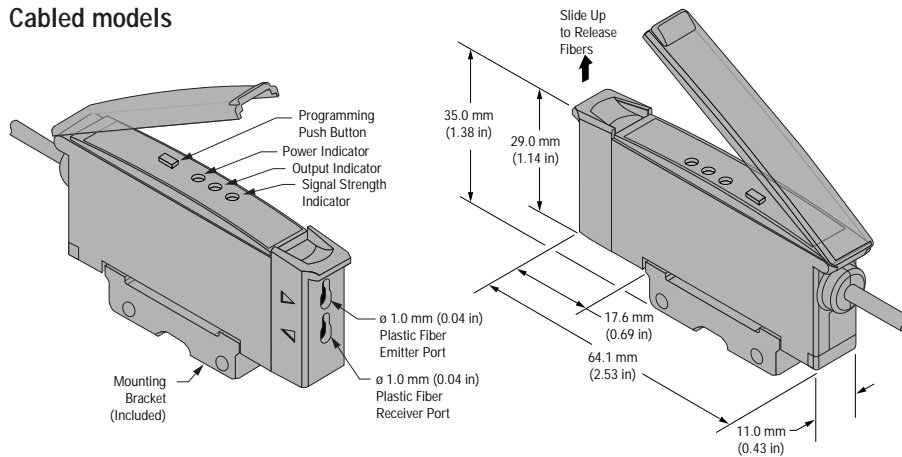

Quick disconnect models

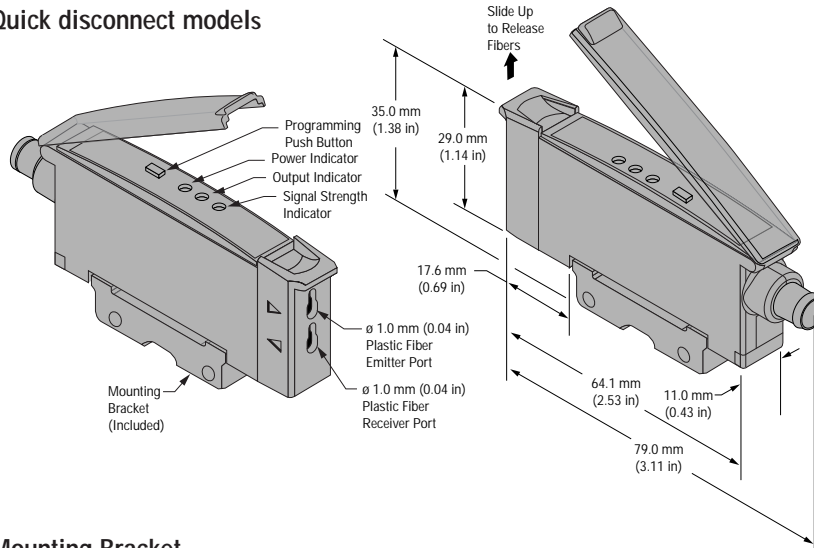

Plastic Fiber Installation:

1. Cut fiber ends per instructions included with the fibers. Slide the fiber gripper up (open). For 0.25 mm or 0.5 mm diameter fibers, insert the adapter (shown below) into the ports as far as it will go.
2. All fibers: Insert the prepared plastic fiber sensor ends gently into the ports as far as they will go.
3. Slide the fiber gripper back down to lock.

Fiber Adaptor

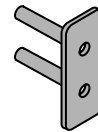

Adaptor (included) is for use with 0.25 mm (0.01") or 0.5 mm (0.02") diameter fibers

Mounting Bracket

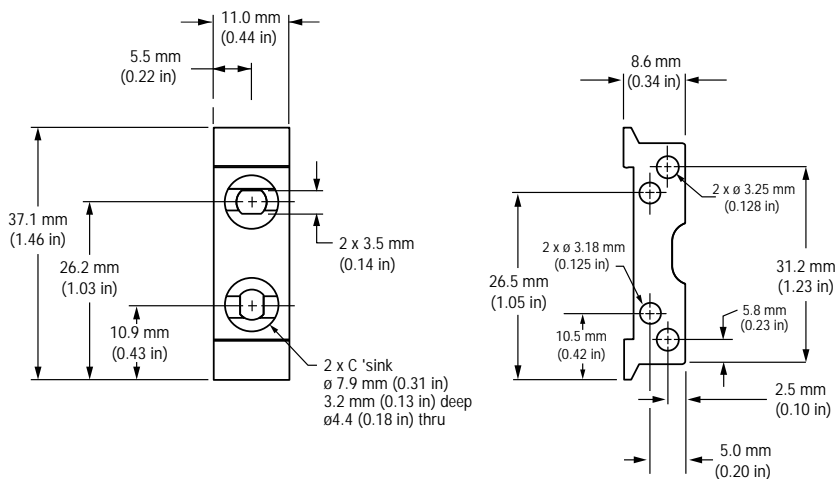

DIN Rail Mounting

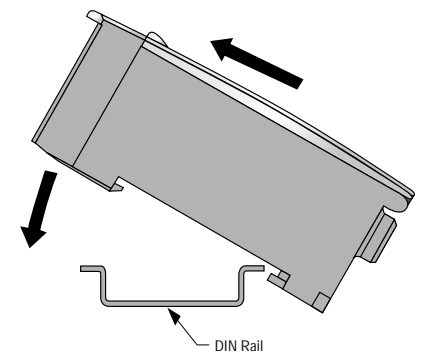

D11E Series Sensors with Visible Green or Blue LED Light Source

Remote Programming

The white wire of the D11E may be connected to a remote switch for the following sensor programming functions:

- 1) Disable or enable the push button
- 2) TEACH mode programming of sensitivity
- 3) Enable or disable the 40-millisecond pulse stretcher.

A remote programming switch is connected between the white wire and dc common (see hookup diagrams on page 6). The switch may be either a normally-open contact, or an open-collector NPN transistor which has its emitter connected to dc common.

Programming is accomplished using a specified sequence of input pulses. The duration of each pulse is defined as: $0.04 \text{ seconds} < T < 0.8 \text{ seconds}$.

The required spacing between adjacent pulses in a sequence (e.g. a "double-pulse") is: $0.04 < T < 0.8 \text{ seconds}$. The timing diagrams, (right) illustrate the input requirements.

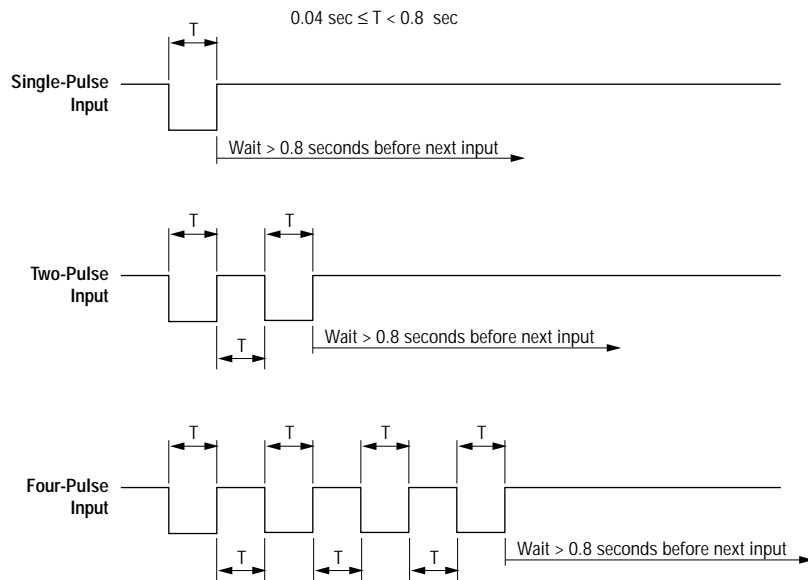

Disable or Enable the Push Button:

When remote programming is used, exclusively, it may be beneficial to disable the push button on the D11E to increase the security of the settings.

- 1) To disable the push button:
Pulse the remote input four times (see timing diagram, above).
- 2) To enable the push button at a later date:
Pulse the input four times (again).

Set Sensitivity via the **TEACH** mode:

- 1) Present the first (output "on") sensing condition to the sensor and pulse the remote input once.
- 2) Present the second (output "off") sensing condition to the sensor and pulse the remote input once. The three LED indicators will flash simultaneously one to four times to indicate relative sensing contrast (see page 3), and the sensor will return to RUN mode.

Enable or Disable the 40-millisecond Pulse Stretcher:

- 1) Pulse the remote input two times (see timing diagram). The status of the pulse stretcher is indicated by the red LED: The red LED will be lit, steadily, if the pulse stretcher is "on"; the red LED will double-flash if the pulse stretcher is "off".
- 2) Pulse the remote input once to toggle the the pulse stretcher "on" or "off".
- 3) Pulse the remote input two times to save the setting and return to the RUN mode.

WARRANTY: Banner Engineering Corporation warrants its products to be free from defects for one year. Banner Engineering Corporation will repair or replace, free of charge, any product of its manufacture found to be defective at the time it is returned to the factory during the warranty period. This warranty does not cover damage or liability for the improper application of Banner products. This warranty is in lieu of any other warranty either expressed or implied.