



WORLD-BEAM® QS18 Adjustable-Field Sensors with Foreground Suppression

Compact sensors featuring extended range and foreground suppression mode

Features



- Exceptional optical performance; up to 200 mm sensing range in compact QS18 housing
- Foreground suppression models for reliable detection when a fixed background is present and the object color or shape varies
- Objects detected to the face of the sensor (no dead zone)
- Simple multi-turn screw adjustment of cutoff distance
- Enhanced immunity to fluorescent lights
- Crosstalk immunity algorithm allows two sensors to be used in close proximity
- Visible red emitter



Adjustable-Field
Foreground Suppression

Models - Foreground Suppression

Long Range Models			
Models*	Supply Voltage	Sensing Range	Output Type
QS18VN6AFF200	10 to 30V dc	Adjustable Cutoff: 30 to 200 mm	NPN
QS18VP6AFF200			PNP
QS18AB6AFF200			Bipolar (1 NPN & 1 PNP)

*Only standard 2 m (6.5') cable models are listed.

- For 9 m (30') cables: add suffix "**W/30**" to the model number (e.g., **QS18VN6AFF200 W/30**).
- For 150 mm (6") pigtail with a 4-pin Pico-style connector, add suffix "**Q**" to the model number (e.g., **QS18VN6AFF200Q**)
- For 150 mm (6") pigtail with a 4-pin Euro-style connector, add suffix "**Q5**" to the model number (e.g., **QS18VN6AFF200Q5**)



Overview

Banner's WORLD-BEAM® QS18 Adjustable-Field Sensors with Foreground Suppression detect the light reflected from the background. The output changes when the light from the background is blocked.

In general, if the background is fixed and the color or shape of the objects in the foreground vary, foreground suppression mode will provide reliable detection. A foreground suppression sensor uses the background in the same way a retroreflective sensor would use a reflector. The sensor output will change whenever an object passes between itself and the background.

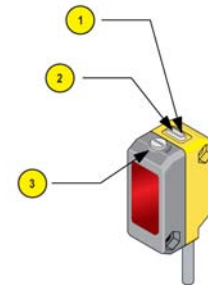

Figure 1. Sensor Features

1. Green: Power Indicator
2. Yellow: Light Sensed Indicator (Flashes for Marginal Conditions)
3. Cutoff Point Adjustment Screw

Sensor Installation

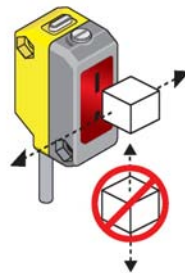

Figure 2. Required Orientation of Object to Sensor



WARNING . . . Not To Be Used for Personnel Protection

Never use this product as a sensing device for personnel protection. Doing so could lead to serious injury or death

This product does NOT include the self-checking redundant circuitry necessary to allow its use in personnel safety applications. A sensor failure or malfunction can cause either an energized or deenergized sensor output condition. Consult your Banner Safety Products catalog for safety products that meet OSHA, ANSI and IEC standards for personnel protection.

Sensor Setup - Foreground Suppression

1. Mount the sensor within 200 mm of the fixed background.
2. Turn adjustment pot **clockwise** until it clicks (5 turns).
3. Turn the adjustment pot **counter-clockwise** until the yellow indicator turns **on**. This places the cutoff distance in front of the fixed background (see figure 3).
4. Place the application's darkest object into the sensor's field of view at the maximum sensor to object distance, and verify that the yellow indicator turns **off**. The sensor is optimized for detecting thin objects close to the fixed background and is ready for operation.

For maximum sensing reliability in applications with variations in background position or color (i.e. conveyor belts with flutter), follow these additional steps.

5. Continuing from step 4, turn adjustment pot **counter-clockwise**, counting the revolutions, until the yellow indicator turns **on**.
 6. Turn adjustment pot **clockwise** half the number of revolutions from step 5. This will place the cutoff distance midway between the object and the background. The sensor is optimized for reliable detection in applications with thick objects and modest variation in background.
- The sensor is ready for operation.

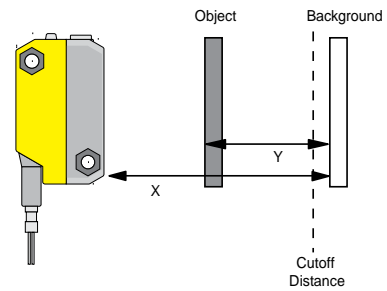

X: Distance to Background
 Y: Minimum Separation Between Object and Background

Figure 3: Set cutoff distance in front of the fixed background

Setup Example

Foreground Suppression Mode (also called Background Detection): The light reflected off the background is detected. The output changes when the light from the background is blocked.

In general, if the background is fixed and the color or shape of the objects in the foreground vary, foreground suppression mode will provide reliable detection. A foreground suppression sensor uses the background in the same way a retroreflective sensor would use a reflector. The sensor output will change whenever an object passes between itself and the background.

To ensure reliable foreground suppression, a minimum separation distance between the object and the background is necessary. See "Minimum Separation Distance Between Object and Background: Foreground Suppression Mode" (Figure 6) to determine the minimum separation distance.

Example: The sensor is positioned above a black conveyor belt at a distance of 150 mm. The objects on the conveyor are boxes of varying colors. According to Figure 6, the box height must be greater than 10 mm for reliable detection against a black background. In this application, reliable detection will be achieved when set up according to the procedure outlined in [Sensor Setup - Foreground Suppression](#) on page 3.

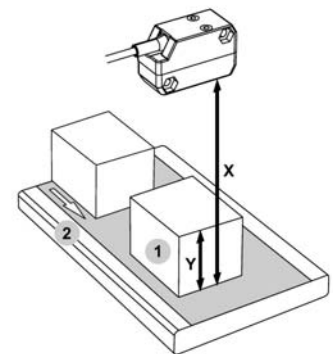

1. Object
 2. Background (Conveyor)
 X: Distance to Background = 150 mm
 Y: Minimum Separation Between Object and Background > 10 mm

Figure 4. Foreground Suppression Mode application example

Output States

Foreground Suppression Mode			
Sensor Model Type	Output	Object Between Sensor Face and Cutoff Distance	No Object Between Sensor Face and Fixed Background
All Models	Yellow Indicator Light	OFF	ON
Complementary Models	Black Wire (Pin 4)	OFF	ON
	White Wire (Pin 2)	ON	OFF
Bipolar Models	Black Wire (Pin 4)	OFF	ON
	White Wire (Pin 2)	OFF	ON

Performance Curves

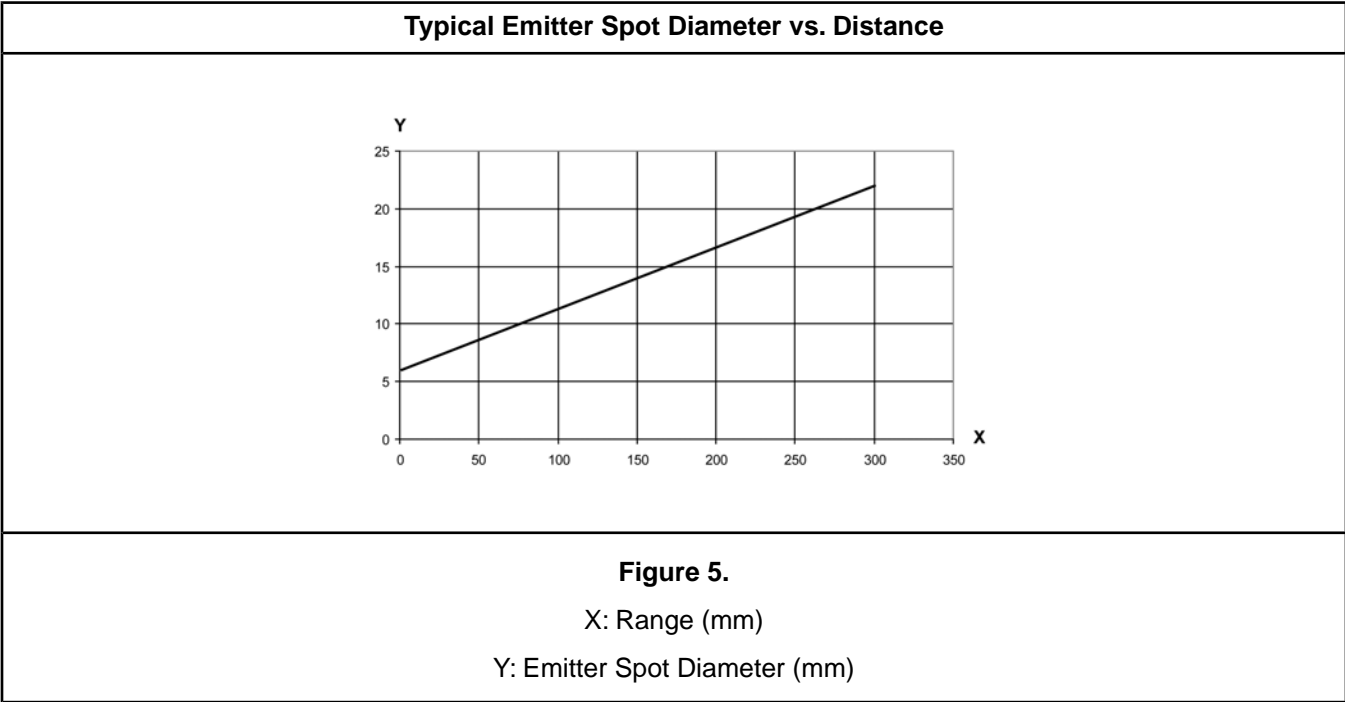

Minimum Separation Distance Between Object and Background: Foreground Suppression Mode

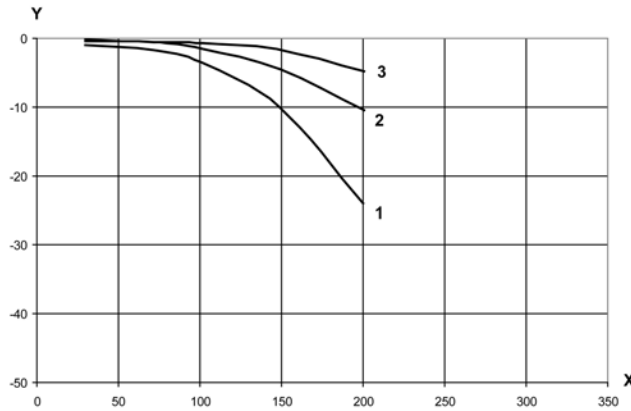
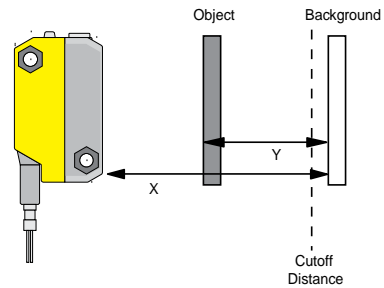

Figure 6.

X: Distance to Background (mm)

Y: Minimum Separation Between Object and Background (mm)

- 1: Black object/ White, Gray, or Black background
- 2: Gray object/ Gray background
- 3: White object/ White background



Excess Gain Curves

Excess Gain Curve with 30 mm Cutoff (based on 90% White Card)

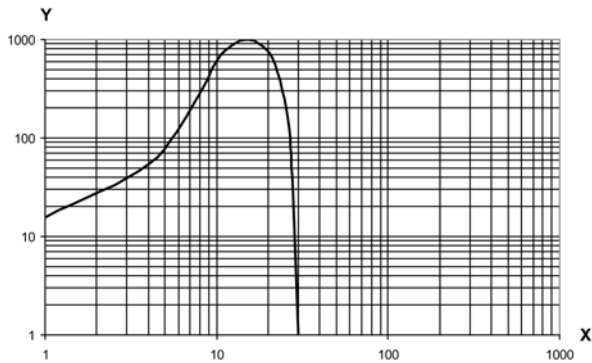

Excess Gain Curve with 200 mm Cutoff (based on 90% White Card)

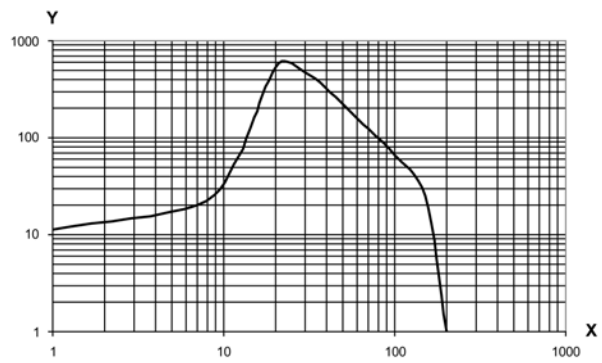



Figure 8.

X: Cutoff Range (mm)

Y: Excess Gain

Specifications

Feature	Description
Supply Voltage	10 to 30V dc (10% maximum ripple within specified limits) at less than 27 mA, exclusive of load; Protected against reverse polarity and transient voltages
Sensing Beam	Visible red LED, 660 nm
Output Configuration	<p>Solid-state complementary; NPN (sinking), PNP (sourcing), or bipolar (both sinking and sourcing) depending on model;</p> <p>Rating: 100 mA total output current</p> <p>Off-state leakage current:</p> <ul style="list-style-type: none"> • NPN: less than 200 μA @ 30V dc (see Application Note 1) • PNP: less than 10 μA @ 30V dc <p>ON-state saturation voltage:</p> <ul style="list-style-type: none"> • NPN: less than 1.6V @ 100 mA • PNP: less than 3.0V @ 100 mA <p>Protected against false pulse on power-up and continuous overload or short circuit of outputs</p>
Output Response	2.5 millisecond ON/OFF; 200 ms delay on power-up; outputs do not conduct during this time
Repeatability	250 μ s
Adjustments	Five-turn adjustment screw sets cutoff distance between min. and max. positions, clutched at both ends of travel
Indicators	<p>2 LED indicators on sensor top:</p> <p>Green ON steady: Power ON</p> <p>Yellow ON steady: Light sensed Yellow flashing: Marginal sensing condition</p>
Construction Materials	ABS housing, acrylic lens cover; PVC cable, nickel-plated brass connector, acetal adjustment pot
Environmental Rating	IEC IP67; NEMA 6; UL Type 1
Connections	2 m (6.5') 4-wire PVC cable, 9 m (30') PVC cable, or 4-pin Pico-style or Euro-style 150 mm (6") pigtail QD, depending on model
Operating Conditions	<p>Temp: -20° to +55° C (-4° to 131° F) Relative Humidity: 95% @ 50° C (non-condensing)</p>
Application Notes	<ol style="list-style-type: none"> 1. NPN off-state leakage current is < 200 μA for load resistances > 3 kΩ or optically isolated loads. For load current of 100 mA, leakage is < 1% of load current. 2. For emitter spot alignment, cover the receiver (top lens position) to temporarily turn emitter to maximum brightness. 3. For mirror-like objects, minimize the sensor to object mounting distance and tilt the sensor so reflected light is directed away from the sensor when the object is present.
Certifications	 CE, UL pending

Dimensions

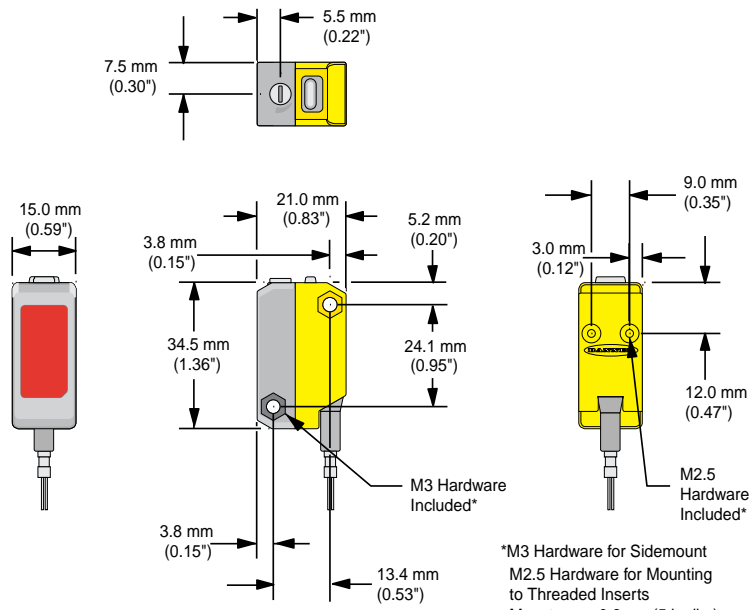

- (2) M3 x 0.5 x 20 mm ss screw
- (2) M3 x 0.5 ss hex nut
- (2) M3 ss washer
- (2) M2.5 x 0.45 x 5 mm ss screw
- (2) M2.5 ss washer

Hookups

NPN (Sinking) Outputs

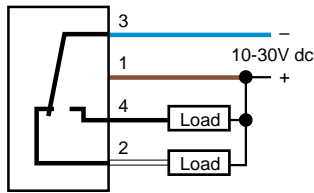

PNP (Sourcing) Outputs

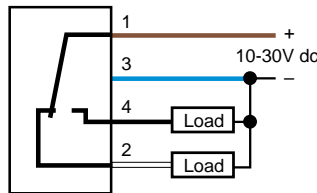

Bipolar Outputs

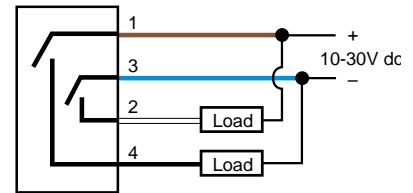

- Wiring Key:**
- 1 = Brown
 - 2 = White
 - 3 = Blue
 - 4 = Black

Quick-Disconnect (QD) Cordsets

Style	Model	Length	Dimensions	Pinout
4-pin Pico-style straight, Snap-on Connector	PKG4-2	2 m (6.5')		

Style	Model	Length	Dimensions	Pinout
4-pin Euro-style straight, Threaded Connector	MQDC-406 MQDC-415 MQDC-430	2 m (6.5') 5 m (15') 9 m (30')		

Mounting Brackets

SMBQS18A	<ul style="list-style-type: none"> • Nickel-plated die-cast zinc • Wrap-around bracket 	
SMBQS18AF	<ul style="list-style-type: none"> • 14 ga., 304 stainless steel • Right-angle mounting bracket 	