



Cutler-Hammer

NFX9000 Adjustable Frequency Drives

User Manual

February 2006



February 2006

Important Notice – Please Read

The product discussed in this literature is subject to terms and conditions outlined in Eaton Electrical Inc. selling policies. The sole source governing the rights and remedies of any purchaser of this equipment is the relevant Eaton Electrical Inc. selling policy.

NO WARRANTIES, EXPRESS OR IMPLIED, INCLUDING WARRANTIES OF FITNESS FOR A PARTICULAR PURPOSE OR MERCHANTABILITY, OR WARRANTIES ARISING FROM COURSE OF DEALING OR USAGE OF TRADE, ARE MADE REGARDING THE INFORMATION, RECOMMENDATIONS AND DESCRIPTIONS CONTAINED HEREIN. In no event will Eaton Electrical Inc. be responsible to the purchaser or user in contract, in tort (including negligence), strict liability or otherwise for any special, indirect, incidental or consequential damage or loss whatsoever, including but not limited to damage or loss of use of equipment, plant or power system, cost of capital, loss of power, additional expenses in the use of existing power facilities, or claims against the purchaser or user by its customers resulting from the use of the information, recommendations and descriptions contained herein.

The information contained in this manual is subject to change without notice.

Cover Photo: Cutler-Hammer® NFX9000 AF Drive.

Table of Contents

SAFETY	iii
Definitions and Symbols	iii
Hazardous High Voltage	iii
Warning and Caution	iv
CHAPTER 1 — OVERVIEW	1-1
How to Use This Manual	1-1
Receiving and Inspection	1-1
Catalog Number Selection	1-2
Dimensions	1-3
Technical Data	1-4
CHAPTER 2 — POWER AND CONTROL WIRING	2-1
Basic Wiring	2-1
Wiring Notes	2-3
CHAPTER 3 — PARAMETERS	3-1
Parameter Lists	3-1
APPENDIX A — FAULT CODES	A-1
APPENDIX B — COMMUNICATION ADDRESS DEFINITION	B-1

List of Figures

Figure 1-1: NFX9000 AF Drive Dimensions	1-3
Figure 2-1: Basic Wiring	2-1
Figure 2-2: Main Circuit Wiring	2-2
Figure 2-3: Control Circuit Wiring	2-3
Figure 2-4: Ground Terminals Connected in Parallel	2-3

List of Tables

Table 1-1: NFX9000 AF Drive Catalog Numbering System	1-2
Table 1-2: NFX9000 Specifications	1-4
Table 3-1: Group 0 — User Parameters	3-1
Table 3-2: Group 1 — Basic Parameters	3-2
Table 3-3: Group 2 — Operation Method Parameters	3-3
Table 3-4: Group 3 — Output Function Parameters	3-3
Table 3-5: Group 4 — Input Function Parameters	3-4
Table 3-6: Group 5 — Multi-Step Speed and PLC Parameters	3-5
Table 3-7: Group 6 — Protection Parameters	3-5
Table 3-8: Group 7 — Motor Parameters	3-7
Table 3-9: Group 8 — Special Parameters	3-7
Table 3-10: Group 9 — Communication Parameters	3-8
Table A-1: Common Problems and Solutions	A-1
Table B-1: Common Address Definition	B-1

February 2006

Safety

Read this manual thoroughly and make sure you understand the procedures before you attempt to install, set up or operate this Cutler-Hammer® NFX9000 Adjustable Frequency Drive from Eaton's electrical business.

Definitions and Symbols

 WARNING

This symbol indicates high voltage. It calls your attention to items or operations that could be dangerous to you and other persons operating this equipment. Read the message and follow the instructions carefully.



This symbol is the "Safety Alert Symbol." It occurs with either of two signal words: CAUTION or WARNING, as described below.

 WARNING

Indicates a potentially hazardous situation which, if not avoided, can result in serious injury or death.

 CAUTION

Indicates a potentially hazardous situation which, if not avoided, can result in minor to moderate injury, or serious damage to the product. The situation described in the CAUTION may, if not avoided, lead to serious results. Important safety measures are described in CAUTION (as well as WARNING).

Hazardous High Voltage

 WARNING

Motor control equipment and electronic controllers are connected to hazardous line voltages. When servicing drives and electronic controllers, there may be exposed components with housings or protrusions at or above line potential. Extreme care should be taken to protect against shock.

- Stand on an insulating pad and make it a habit to use only one hand when checking components.
- Always work with another person in case an emergency occurs.
- Disconnect power before checking controllers or performing maintenance.
- Be sure equipment is properly grounded.
- Wear safety glasses whenever working on electronic controllers or rotating machinery.

Warning and Caution

 **WARNING**

Ensure that all screws are tightened to the proper torque rating.

 **CAUTION**

Do not connect the AC input to any of the U/T1, V/T2 or W/T3 terminals as it will damage the drive.

February 2006

Chapter 1 — Overview

This manual provides instructions for the installation and operation of Cutler-Hammer® NFX9000 Adjustable Frequency Drives from Eaton's electrical business.

This chapter describes the purpose and contents of this manual, the receiving inspection recommendations and the NFX9000 catalog numbering system.

How to Use This Manual

The purpose of this manual is to provide you with information necessary to install, set and customize parameters, start up, troubleshoot and maintain the NFX9000 drive.

To provide for safe installation and operation of the equipment, read the safety guidelines at the beginning of this manual and follow the procedures outlined in the following chapters before connecting power to the NFX9000. Keep this operating manual handy and distribute to all users, technicians and maintenance personnel for reference.

Chapter 1 — Overview is the chapter you are reading now.

Chapter 2 — Power and Control Wiring

Chapter 3 — Parameters

Appendix A — Fault Codes

Receiving and Inspection

This NFX9000 drive has gone through rigorous quality control tests at the factory before shipment. Since many things may happen during shipping, please do the following after receiving the AC motor drive:

- Inspect the unit to ensure it was not damaged during shipment.
- Make sure that the catalog number on the nameplate corresponds with the catalog number of your order.

If the delivery does not correspond to your order, please contact your Eaton representative.

Catalog Number Selection

Table 1-1: NFX9000 AF Drive Catalog Numbering System

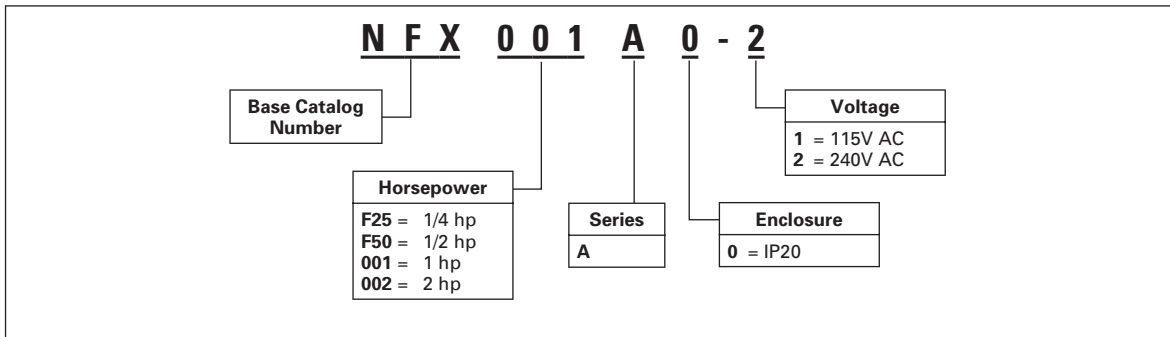

February 2006

Dimensions

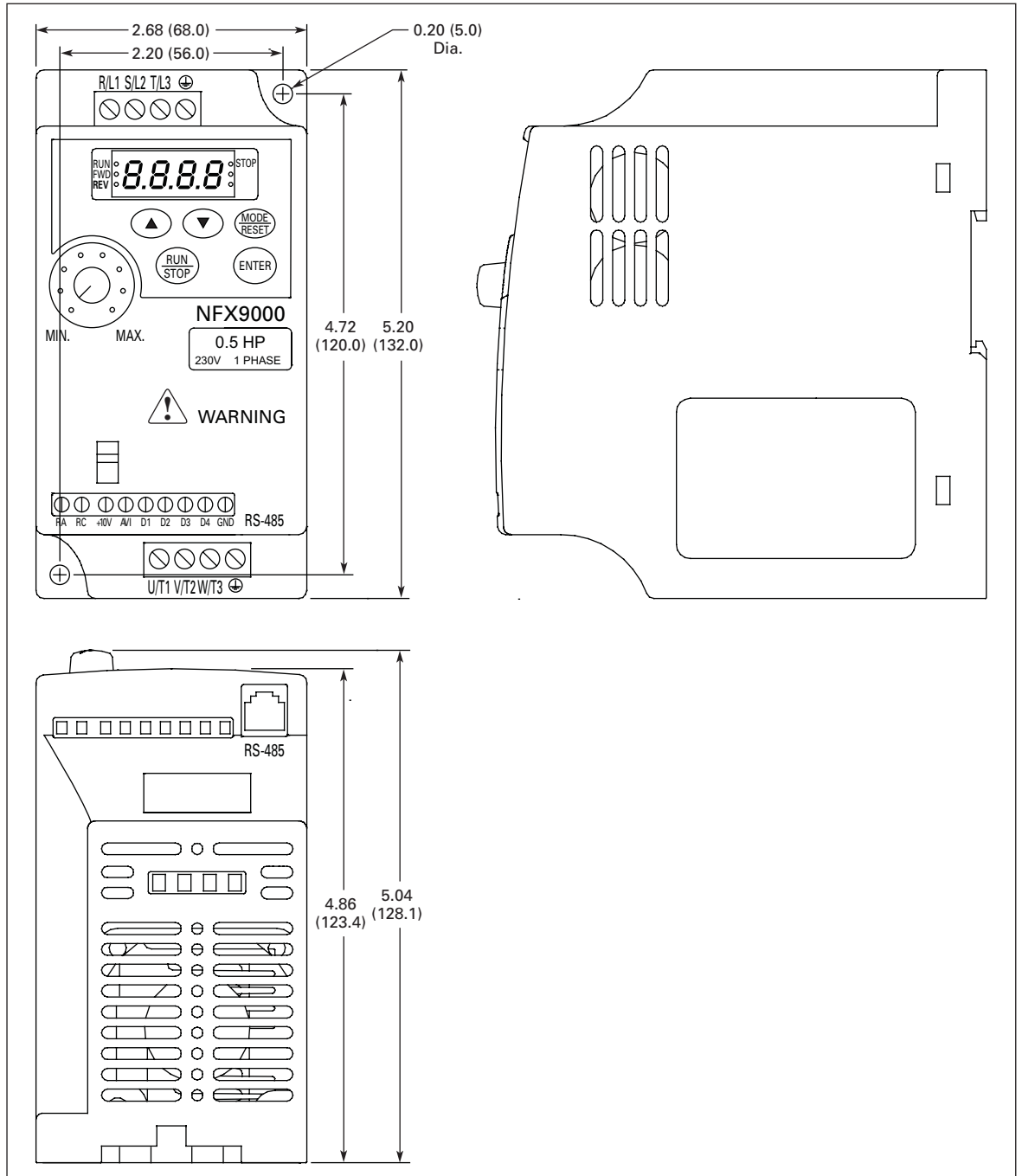

Figure 1-1: NFX9000 AF Drive Dimensions

Technical Data

Table 1-2: NFX9000 Specifications

Description	115V		230V			
	NFXF25A0-1	NFXF50A0-1	NFXF25A0-2	NFXF50A0-2	NFX001A0-2	NFX002A0-2
Maximum Motor Output (hp)	0.25	0.50	0.25	0.50	1	2
Maximum Motor Output (kW)	0.2	0.4	0.2	0.4	0.7	1.5
Output Ratings						
Rated Output Capacity (KVA)	.6	1.0	.6	1.0	1.6	2.7
Rated Output Current (A)	1.6	2.5	1.6	2.5	4.2	7.0
Maximum Output Voltage (V)	3-phase corresponds to double input voltage		3-phase corresponds to input voltage			
Rated Frequency (Hz)	1.0 – 400					
Power						
Rated Input Current (A)	6	9	4.9	6.5	9.7	9
Input Voltage Tolerance	1-phase, 90 – 132V, 50/60 Hz		1-phase, 180 – 264V, 50/60 Hz			3-phase, 180 – 264V, 50/60 Hz
Frequency Tolerance	±5%					
Control Characteristics						
Control System	SVPWM (Sinusoidal Pulse Width Modulation) carried frequency, 3 kHz – 10 kHz					
Output Frequency Resolution	.1 Hz					
Torque Characteristics	Starting torque can be 150% at 5 Hz including the auto-torque, auto-slip compensation					
Overload Endurance	150% of rated current for 1 minute					
Acceleration/Deceleration Time	.1 – 600 seconds (can be set individually)					
V/F Pattern	Adjustable					
Stall Prevention Level	20 – 200% of setting for rated current					
Operating Characteristics						
Frequency Setting — Keypad	Set by using ▲ and ▼ keys or Potentiometer					
Frequency Setting— External Signal	Potentiometer = 5 kΩ/.5W, DC 0 to +10V (input impedance = 47 kΩ), 4 – 20 mA (output impedance = 250Ω) Digital inputs = 1 to 3 (three steps: JOG, UP or DOWN command) Communication setting					
Operation Setting — Keypad	Set by using RUN/STOP keys					
Operation Setting — External Signal	RS-485 communication port; D1, D2, D3 and D4 can be combined to offer various modes of operation					
Digital input Signal	Multi-step selection 0 to 3, jog, accel./decel. inhibit, first/second accel./decel. switch, counter, PLC operation, external base block (NC, NO) selection					
Multi-function Output Signal	Drive operating, frequency attained, non-zero speed, base block, fault indication, local/remote indication and PLC operation indication					
Functions						
Miscellaneous	AVR, S-curve, overvoltage stall protection, DC braking, fault records, adjustable carried frequency, starting frequency setting for DC braking, over-current stall prevention, momentary power loss restart, reverse inhibition, frequency limits and parameter lock/reset					
Protection	Overvoltage, over current, undervoltage, overload, overheating, electronic thermal, and self-testing					
Filtration	EMI filter					
Cooling	Forced air					
Environment						
Installation Location	Altitude = 1,000m or below Keep away from any corrosive gas, liquid and dust					
Ambient Temperature	14 to 104°F (-10 to -40°C), non-condensing and not frozen					
Storage Temperature	-4 to 140°F (-20 to 60°C)					
Ambient Humidity	Below 90% relative humidity (non-condensing)					
Vibration	9.80665 m/s ² (1G) at less than 20 Hz, 5.88 m/s ² (.6G) at 20 – 50 Hz					

February 2006

Chapter 2 — Power and Control Wiring

Basic Wiring

Users must connect wiring according to the circuit diagram shown in **Figure 2-1**. Please follow all national and state wiring codes when wiring the drive.

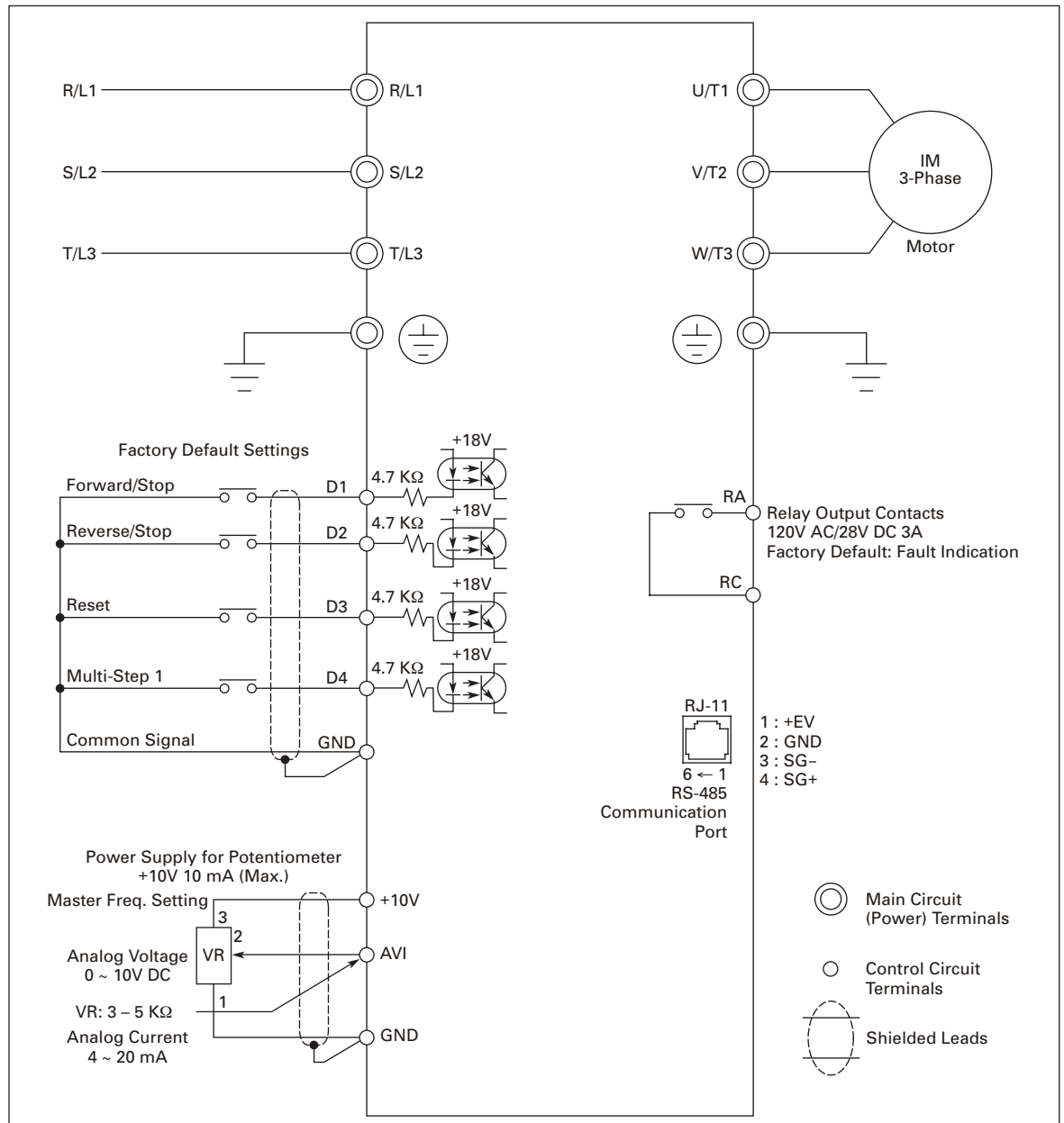

Figure 2-1: Basic Wiring

Note: Do not plug a modem or telephone line into the RS-485 communication port or permanent damage may result. Terminals 1 and 2 are the power source for the optional copy keypad and should not be used while using the RS-485 communication.

- Use power terminals R/L1 and S/L2 for single-phase connection to models: NFXF25A0-1, NFXF50A0-1, NFXF25A0-2, NFXF50A0-2 or NFX001A0-2.
- Use power terminals R/L1, S/L2 and T/L3 for three-phase connection to models: NFXF25A0-2, NFXF50A0-2, NFX001A0-2 or NFX002A0-2.
- Single-phase power must not be used for model NFX002A0-2.

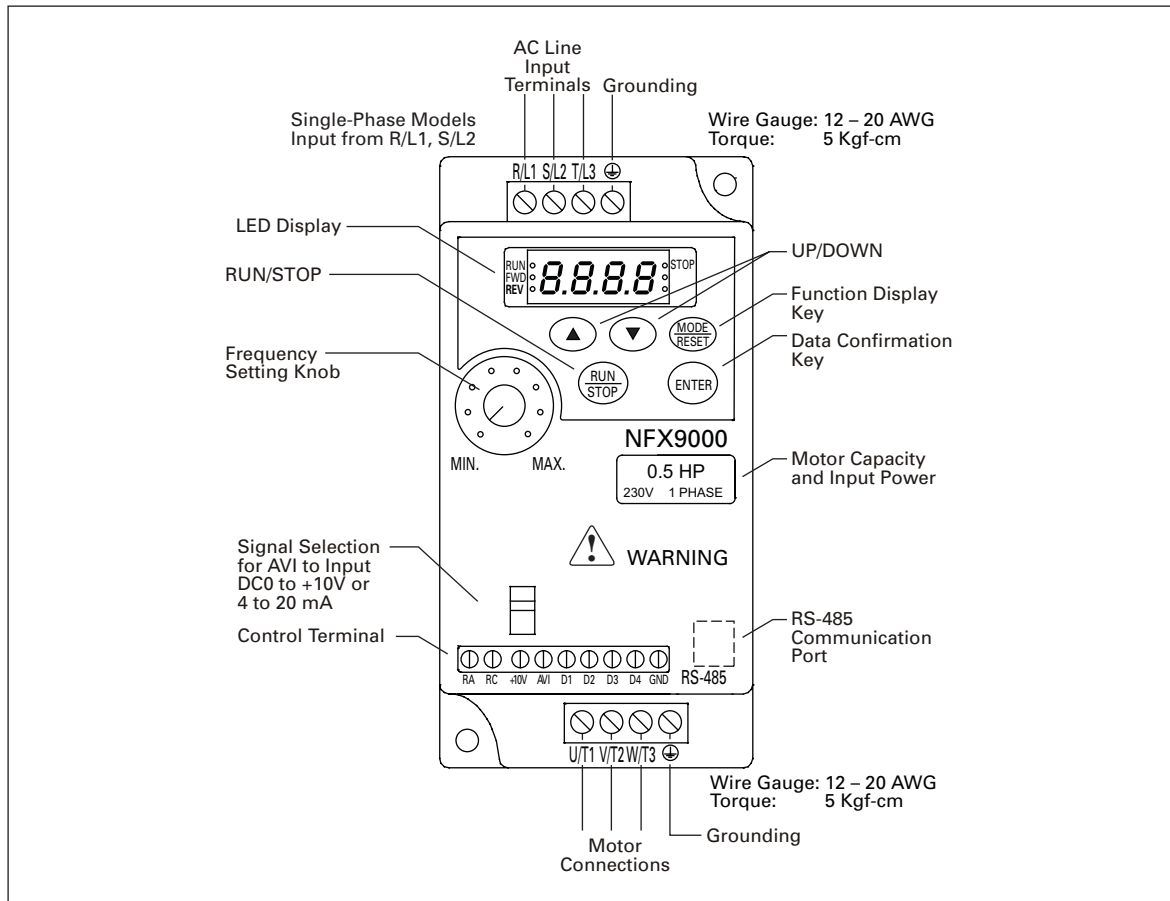

Figure 2-2: Main Circuit Wiring

February 2006

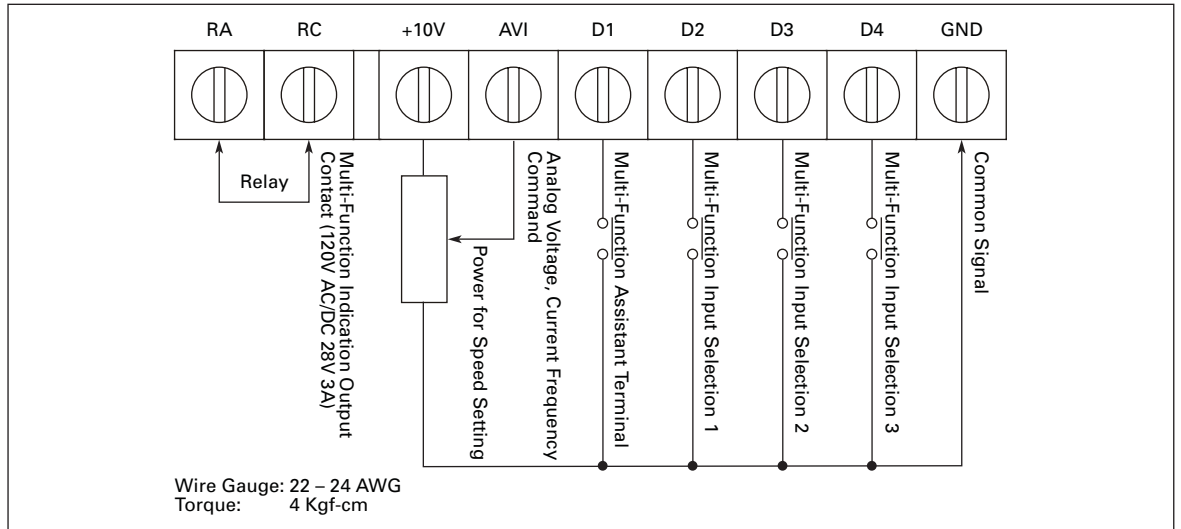

Figure 2-3: Control Circuit Wiring

Wiring Notes

WARNING

Ensure that all screws are tightened to the proper torque rating.

CAUTION

Do not connect the AC input to any of the U/T1, V/T2 or W/T3 terminals as it will damage the drive.

Multiple NFX9000 drives can be installed in one location. Please read the following prior to installation:

1. Follow all national and local electrical, construction and safety codes during installation.
2. Ensure the appropriate protective devices (circuit breaker or fuses) are connected between the power supply and drive.
3. Make sure the leads are connected correctly and the drive is properly grounded. (Ground resistance should not exceed .1Ω.)
4. Use ground leads that comply with AWG/MCM standards and keep them as short as possible.
5. For multiple drive installations, make sure to ground all units directly to a common ground terminal. The ground terminals may be connected in parallel as shown in **Figure 2-4**. (Ensure there are no ground loops.)

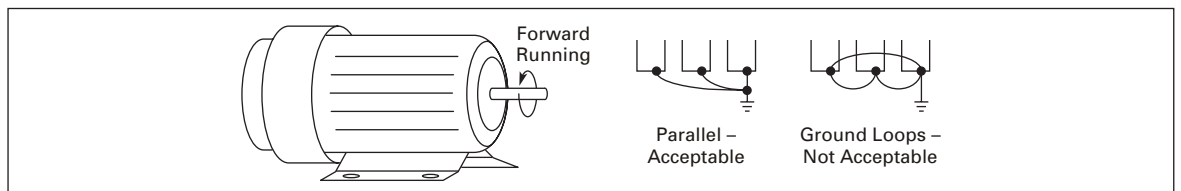

Figure 2-4: Ground Terminals Connected in Parallel

6. For normal operation, make sure drive output terminals U/T1, V/T2 and W/T3 are connected to motor terminals U, V and W (respectively). The motor will rotate counterclockwise as viewed from the shaft ends of the motor when a forward operation command is received. To reverse the direction of motor rotation, switch any two of the motor leads.
7. Make sure the power source is capable of supplying the correct voltage and required current to the drive.
8. Do not attach or remove wiring when power is applied to the drive.
9. Do not monitor the signals on the circuit board while the drive is in operation.
10. Route the power and control wires separately or at right angles to each other.
11. If required to reduce electro-magnetic interference (EMI), install the filter as close as possible to the U/T1, V/T2 or W/T3 side of the drive.

Note: Do not use a capacitor or L-C filter (inductance/capacitance) or an R-C filter (resistance/capacitance).

12. When using a GFCI (ground fault circuit interrupt), select a current sensor with a minimum current of 200 mA and a minimum detection time of .1 second to avoid nuisance tripping.

February 2006

Chapter 3 — Parameters

Parameter Lists

Table 3-1: Group 0 — User Parameters

Code	Parameter	Min.	Max.	Unit	Default	Cust	Note
0-00	Identity code of drive (read only)	1	6				1: 40W 2: 100W 3: 200W 4: 400W 5: 750W 6: 1.5 kW
0-01	Rated current display (read only)	—	—				40W: .4A 100W: .8A 200W: 1.6A 400W: 2.5A 750W: 4.2A 1.5 kW: 7.0A
0-02	Parameter reset				0		10: Reset parameters to factory setting
0-03 ^①	Start-up display of drive	0	3		0		0: F (frequency command) 1: H (output frequency) 2: U (user-defined unit) 3: A (output current)
0-04 ^①	User-defined unit	0	4		0		0: Display user-defined unit (u) 1: Display counter value (C) 2: Display process operation (1=tt) 3: Display DC bus voltage (U) 4: Display output voltage (E)
0-05 ^①	User-defined coefficient (K)	0.1	160		1.0		0.1 – 160
0-06	Software version	—	—		##		Read only
0-07	Password input	0	999		0		0 – 999
0-08	Password configuration	0	999		0		0 – 999

^① The parameter may be set during operation.

Table 3-2: Group 1 — Basic Parameters

Code	Parameter	Min.	Max.	Unit	Default	Cust	Note
1-00	Maximum operation frequency	50.0	400	Hz	60.0		50.0 – 400 Hz
1-01	Maximum voltage frequency	10.0	400	Hz	60.0		10.0 – 400 Hz
1-02	Maximum output voltage	2.0	255	V	220		2.0 – 255V
1-03	Mid-point frequency	1.0	400	Hz	1.0		1.0 – 400 Hz
1-04	Mid-point voltage	2.0	255	V	12.0		2.0 – 255V
1-05	Minimum output frequency	1.0	60.0	Hz	1.0		1.0 – 60 Hz
1-06	Minimum output voltage	2.0	255	V	12.0		2.0 – 255V
1-07	Upper bound of frequency	1	110	%	100		1 – 110%
1-08	Lower bound of frequency	0	100	%	0		0 – 100%
1-09 ①	Acceleration time 1 (Tacc1)	0.1	600	sec.	10.0		0.1 – 600 seconds
1-10 ①	Deceleration time 1 (Tdec1)	0.1	600	sec.	10.0		0.1 – 600 seconds
1-11 ①	Acceleration time 2	0.1	600	sec.	10.0		0.1 – 600 seconds
1-12 ①	Deceleration time 2	0.1	600	sec.	10.0		0.1 – 600 seconds
1-13 ①	JOG acceleration time	0.1	600	sec.	10.0		0.1 – 600 seconds
1-14 ①	JOG deceleration time	0.0	600	sec.	10.0		0.0 – 600 seconds
1-15 ①	JOG frequency	1.0	400	Hz	6.0		1.0 – 400 Hz
1-16	Auto acceleration/ deceleration	0	5		0		0: Linear accel./decel. 1: Auto accel., linear decel. 2: Linear accel., auto decel. 3: Auto accel./decel. 4: Linear accel., auto decel. (stall prevention during deceleration) 5: Auto accel./decel. (stall prevention during deceleration)
1-17	S-curve setting in acceleration	0	7		0		0 – 7
1-18	S-curve setting in deceleration	0	7		0		0 – 7

① The parameter may be set during operation.

February 2006

Table 3-3: Group 2 — Operation Method Parameters

Code	Parameter	Min.	Max.	Unit	Default	Cust	Note
2-00	Source of frequency command	0	4		0		0: Digital keypad 1: 0 – 10V from AVI 2: 4 – 20 mA from AVI 3: Controlled by V.R. on drive 4: RS-485 communication interface
2-01	Source of operation command	0	4		0		0: By digital keypad 1: By external terminals, keypad STOP enable 2: By external terminals, keypad STOP disable 3: By RS-485 communication interface, keypad STOP enable 4: By RS-485 communication interface, keypad STOP disable
2-02	Stop method	0	1		0		0: Ramp stop 1: Coast stop
2-03	Carrier frequency	3	10K	Hz	10		3 – 10K Hz
2-04	Reverse operation inhibit	0	2		0		0: Enable reverse 1: Disable reverse 2: Disable forward
2-05	ACI (4 – 20 mA) input loss detection	0	2		0		0: Decelerate to 0 Hz 1: Stop immediately, display EF 2: Run with the last frequency
2-06	Line start lockout	0	1		0		0: Enable 1: Disable

Table 3-4: Group 3 — Output Function Parameters

Code	Parameter	Min.	Max.	Unit	Default	Cust	Note
3-00	Desired frequency attained	1.0	400	Hz	1.0		1.0 – 400 Hz
3-01	Terminal count value	0	999		0		0 – 999
3-02	Preliminary count value	0	999		0		0 – 999
3-03	Multi-function relay output	0	16		8		0: Not used 1: AC drive operational 2: Maximum output frequency attained 3: Zero speed 4: Over torque 5: Base-block (B.B.) 6: Low voltage detection 7: AC drive operation mode 8: Fault indication 9: Desired frequency attained 10: PLC program running 11: PLC program step complete 12: PLC program complete 13: PLC program operation pause 14: Terminal count value attained 15: Preliminary count value attained 16: Ready state indicator

Table 3-5: Group 4 — Input Function Parameters

Code	Parameter	Min.	Max.	Unit	Default	Cust	Note
4-00 ^①	Potentiometer bias frequency	0.0	350	Hz	0.0		0.0 – 350 Hz
4-01 ^①	Potentiometer bias polarity	0	1		0		0: Positive bias 1: Negative bias
4-02 ^①	Potentiometer frequency gain	1	200	%	100		1 – 200
4-03	Potentiometer reverse motion enable	0	2		0		0: Not used 1: Reverse motion enable 2: Forward motion only
4-04	Digital Input 1 & 2 (D1 & D2)	0	3		1		0: Not used 1: D1 – FWD/STOP, D2 – REV/STOP 2: D1 – RUN/STOP, D2 – FWD/REV 3: D1, D2, D3 – 3-wire operation control mode
	Note: Setting parameter 4-04 to values 4 – 20 applies to D2 and disables D1	4	20		—		4: External fault, normally open (NO) 5: External fault, normally closed (NC) 6: Reset 7: Multi-step speed command 1 8: Multi-step speed command 2 9: Jog operation 10: Accel./decel. speed inhibit 11: First or second accel./decel. time selection 12: Base block, NO 13: Base block, NC 14: Increase master frequency 15: Decrease master frequency 16: Run PLC program 17: Pause PLC 18: Counter trigger signal 19: Counter reset 20: Select ACI/deselect AVI
4-05	Digital Input 3 (D3) Note: Setting parameter 4-04 to value 3 presets D3 to 3-wire operation	0, 4	20		6		0: Not used 4: External fault, normally open (NO) 5: External fault, normally closed (NC) 6: Reset 7: Multi-step speed command 1 8: Multi-step speed command 2 9: Jog operation 10: Accel./decel. speed inhibit 11: First or second accel./decel. time selection 12: Base block, NO 13: Base block, NC 14: Increase master frequency 15: Decrease master frequency 16: Run PLC program 17: Pause PLC 18: Counter trigger signal 19: Counter reset 20: Select ACI/deselect AVI
4-06	Digital Input 4 (D4)	0, 4	20		7		Same as 4-05.

^① The parameter may be set during operation.

February 2006

Table 3-6: Group 5 — Multi-Step Speed and PLC Parameters

Code	Parameter	Min.	Max.	Unit	Default	Cust	Note
5-00	First step speed frequency	0.0	400	Hz	0		0 – 400 Hz
5-01	Second step speed frequency	0.0	400	Hz	0		0 – 400 Hz
5-02	Third step speed frequency	0.0	400	Hz	0		0 – 400 Hz
5-03	PLC mode	0	4		0		0: Disable PLC operation 1: Execute one program cycle 2: Continuously execute program cycles 3: Execute one program cycle step by step (separate by STOP) 4: Continuously execute one program cycle step by step (separate by STOP)
5-04	PLC forward/reverse motion	0	1		0		0 – 15 0: Forward 1: Reverse
5-05	Time duration step 0	0	65500	sec.	0		0 – 65500 seconds
5-06	Time duration step 1	0	65500	sec.	0		0 – 65500 seconds
5-07	Time duration step 2	0	65500	sec.	0		0 – 65500 seconds
5-08	Time duration step 3	0	65500	sec.	0		0 – 65500 seconds

Table 3-7: Group 6 — Protection Parameters

Code	Parameter	Min.	Max.	Unit	Default	Cust	Note
6-00	Over-voltage prevention level	0	410	V	390		0: Disable, 350 – 410V
6-01	Over-current prevention level	0	200	%	170		0: Disable, 20 – 200%
6-02	Over-torque detection	0	4		0		0: Disable 1: Enabled during constant speed operation; continues until the continuous limit is reached 2: Enabled during constant speed operation; halted after detection 3: Enabled during acceleration; continues before continuous output time limit is reached 4: Enabled during acceleration; halted after over-torque detection
6-03	Over-torque detection level	30	200	%	150		30 – 200%
6-04	Over-torque detection time	0.1	10.0	sec.	0.1		0.1 – 10.0 seconds

Table 3-7: Group 6 — Protection Parameters, continued

Code	Parameter	Min.	Max.	Unit	Default	Cust	Note
6-05	Electronic thermal overload relay	0	2		0		0: Not used 1: Act with standard motor 2: Act with special motor
6-06	Electronic thermal characteristic	30	600	sec.	60		30 – 600 seconds
6-07	Present fault record	0	11		0		0: No fault occurred 1: oc (over-current) 2: ov (over-voltage) 3: oH (overheat) 4: oL (overload) 5: oL1 (electronic thermal) 6: EF (external fault) 7: Reserved 8: Reserved 9: ocA (current exceed during acceleration) 10: ocd (current exceed during deceleration) 11: ocn (current exceed during steady state) 12: Reserved 13: Reserved 14: Reserved 15: CPU failure 1 (cF1) 16: CPU failure 2 (cF2) 17: Reserved 18: Overload (oL2) 19: Auto acc/dec failure (cFA) 20: Software protection enabled (code) 21: Reserved 22: CPU failure (cF3.1) 23: CPU failure (cF3.2) 24: CPU failure (cF3.3) 25: CPU failure (cF3.4) 26: CPU failure (cF3.5) 27: CPU failure (cF3.6) 28: CPU failure (cF3.7) 29: Hardware protection failure (HPF.1) 30: Hardware protection failure (HPF.2) 31: Hardware protection failure (HPF.3)
6-08	Second most recent fault record	0	11		0		Same as 6-07
6-09	Third most recent fault record	0	11		0		Same as 6-07
6-10	Fourth most recent fault record	0	11		0		Same as 6-07
6-11	Fifth most recent fault record	0	11		0		Same as 6-07
6-12	Sixth most recent fault record	0	11		0		Same as 6-07

February 2006

Table 3-8: Group 7 — Motor Parameters

Code	Parameter	Min.	Max.	Unit	Default	Cust	Note
7-00 ^①	Motor-rated current	30	120	%	85		30 – 120%
7-01 ^①	Motor no-load current	0	90	%	50		0 – 90%
7-02 ^①	Torque compensation	0	10		1		0 – 10
7-03 ^①	Slip compensation	0.0	10.0		0.0		0.0 – 10.0

^① The parameter may be set during operation.**Table 3-9: Group 8 — Special Parameters**

Code	Parameter	Min.	Max.	Unit	Default	Cust	Note
8-00	DC braking voltage level	0	30	%	0		0 – 30%
8-01	DC braking time during start-up	0.0	60.0	sec.	0.0		0.0 – 60.0 seconds
8-02	DC braking time during stopping	0.0	60.0	sec.	0.0		0.0 – 60.0 seconds
8-03	Start point for DC braking	0.0	400.0	sec.	0.0		0.0 – 400.0 seconds
8-04	Momentary power loss	0	2		0		0: Stop operation after momentary power loss 1: Continues after momentary power loss; speed search starts with master frequency 2: Continues after momentary power loss; speed search starts with minimum output frequency
8-05	Maximum allowable power loss time	0.3	5.0	sec.	2.0		0.3 – 5.0 seconds
8-06	Base-block time for speed search	0.3	5.0	sec.	0.5		0.3 – 5.0 seconds
8-07	Maximum speed search current level	30	200	%	150		30 – 200%
8-08	Skip frequency 1 upper bound	0.0	400	Hz	0.0		0.0 – 400 Hz
8-09	Skip frequency 1 lower bound	0.0	400	Hz	0.0		0.0 – 400 Hz
8-10	Skip frequency 2 upper bound	0.0	400	Hz	0.0		0.0 – 400 Hz
8-11	Skip frequency 2 lower bound	0.0	400	Hz	0.0		0.0 – 400 Hz
8-12	Skip frequency 3 upper bound	0.0	400	Hz	0.0		0.0 – 400 Hz
8-13	Skip frequency 3 lower bound	0.0	400	Hz	0.0		0.0 – 400 Hz
8-14	Auto restart after fault	0	10		0		0 – 10
8-15	AVR function	0	2		2		0: AVR function enabled 1: AVR function disabled 2: AVR function disabled with deceleration
8-16	Dynamic braking voltage	350	450	V	380		350 – 450V
8-17	DC braking lower bound limit	0.0	400	Hz	0.0		0.0 – 400 Hz

Table 3-10: Group 9 — Communication Parameters

Code	Parameter	Min.	Max.	Unit	Default	Cust	Note
9-00 ^①	Communication address	1	247		1		1 – 247
9-01 ^①	Transmission speed	0	2		1		0: Baud rate 4,800 1: Baud rate 9,600 2: Baud rate 19,200
9-02 ^①	Transmission fault treatment	0	3		0		0: Warn and continue running 1: Warn and ramp to stop 2: Warn and coast to stop 3: No warning and keep running
9-03 ^①	Modbus communication watchdog timer	0	20		0		0: Disable, 1 – 20: 1 – 20 seconds
9-04 ^①	Communication protocol	0	8		0		ASCII mode: 0: 7,N,2 1: 7,E,1 2: 7,O,1 3: 8,N,2 4: 8,E,1 5: 8,O,1 RTU mode: 6: 8,N,2 7: 8,E,1 8: 8,O,1

^① The parameter may be set during operation.

February 2006

Appendix A — Fault Codes

The NFX9000 drive has a comprehensive fault diagnostic system that includes several different alarms and fault messages. Once a fault is detected, the corresponding protective functions will be activated. The following faults are displayed on the AC drive digital keypad. The six most recent faults can be read on the digital keypad display by viewing Parameter 6-07 to Parameter 6-12.

Note: Faults can be cleared by pressing the RESET key on the keypad or Input Terminal.

Table A-1: Common Problems and Solutions

Fault Name	Fault Description	Corrective Action
oc	Drive detects an abnormal increase in current	<ol style="list-style-type: none"> 1. Make sure the motor's horsepower corresponds to the drive's output power. 2. Check the wiring connections between the drive and motor for possible short circuits. Note: If there are any abnormal conditions when operating the drive after the short circuit is removed, consult Eaton. 3. Increase the acceleration time (parameters 1-09 and 1-11). 4. Check for possible excessive loading.
ou	Drive detects that DC bus voltage has exceeded its maximum allowable value	<ol style="list-style-type: none"> 1. Make sure the input voltage falls within the drive's input voltage rating range. 2. Check for possible voltage transients. 3. Increase the deceleration time. (Bus overvoltage may also be caused by motor regeneration.)
oH	Drive's temperature sensor detects excessive heat	<ol style="list-style-type: none"> 1. Ensure that the ambient temperature falls within the specified temperature range. 2. Make sure that the ventilation holes are not obstructed. 3. Remove any foreign objects on the heat-sink and check for possible dirty heat-sink fins. 4. Provide enough spacing for adequate ventilation.
Lu	Drive detects that DC bus voltage has fallen below its minimum value	Make sure the input voltage falls within the drive's input voltage rating range.
oL1	Internal electronic overload trip	<ol style="list-style-type: none"> 1. Check for a possible motor overload. 2. Check electronic thermal overload setting. 3. Increase motor capacity. 4. Reduce the current level so the drive's output current does not exceed the value set by the Motor Rated Current, parameter 7-00.
EF	External terminal EF-GND goes from OFF to ON	When the EF-GND is closed, the output will be turned off (under N.O.E.F.)
oL2	Motor overload	<ol style="list-style-type: none"> 1. Check settings for parameters 6-03 to 6-05. 2. Reduce the motor load. 3. Adjust the over-torque detection setting to an appropriate setting.

Table A-1: Common Problems and Solutions, Continued

Fault Name	Fault Description	Corrective Action
ocA	Over-current during acceleration: <ul style="list-style-type: none"> • Short circuit at motor output • Torque boost too high • Acceleration time too short • Drive's output capacity too small 	<ol style="list-style-type: none"> 1. Make sure the insulation is adequate at the output line. 2. Decrease the torque boost setting in parameter 7-02. 3. Increase the acceleration time. 4. Replace the drive with one that has a higher output capacity (next level hp).
ocd	Over-current during deceleration: <ul style="list-style-type: none"> • Short circuit at motor output • Deceleration time too short • Drive's output capacity too small 	<ol style="list-style-type: none"> 1. Make sure the insulation is adequate at the output line. 2. Increase the deceleration time. 3. Replace the drive with one that has a higher output capacity (next level hp).
ocn	Over-current during steady-state operation: <ul style="list-style-type: none"> • Short circuit at motor output • Sudden increase in motor loading • Drive's output capacity too small 	<ol style="list-style-type: none"> 1. Make sure the insulation is adequate at the output line. 2. Check for possible motor stall. 3. Replace the drive with one that has a higher output capacity (next level hp).
cF1	Internal memory IC cannot be programmed	<ol style="list-style-type: none"> 1. Switch off power supply. 2. Make sure the input voltage falls within the drive's input voltage rating range. 3. Switch on the drive.
cF2	Internal memory IC cannot be read	<ol style="list-style-type: none"> 1. Check the connections between the main control board and the power board. 2. Reset drive to factory defaults.
cF3	Drive's internal circuitry abnormal	<ol style="list-style-type: none"> 1. Switch off power supply. 2. Make sure the input voltage falls within the drive's input voltage rating range. 3. Switch on the drive.
HPF	Hardware protection failure	Consult Eaton.
codE	Software protection failure	Consult Eaton.
cFA	Auto acceleration/deceleration failure	Do not use the auto accel./decel. function.
CE1	Communication error	<ol style="list-style-type: none"> 1. Check the connection between the drive and computer for loose wires. 2. Make sure the communication protocol is properly set.
bb	External base block (When the external input terminal (BB) is active, the drive output will be turned off.)	Disable the connection between external input terminal (BB) and the drive. The drive will begin to run again.
oL	Drive detects excessive drive output current	<ol style="list-style-type: none"> 1. Check whether the motor is overloaded. 2. Reduce torque compensation setting set in parameter 7-02. 3. Increase the drive's output capacity. <p>Note: The drive can withstand up to 150% of the rated current for a maximum of 60 seconds.</p>

February 2006

Appendix B — Communication Address Definition

Table B-1: Communication Address Definition

Content:	Address:	Function:	
AMD Parameters Read, Write	ggnnH	gg means parameter group, nn means parameter number, for example, the address of Pr 4-01 is 0401H. Referencing to Chapter 3 for the function of each parameter. When reading parameter by command code 03H, only one parameter can be read at one time.	
Command	2000H	Bit 1,0	00: No function 01: Stop 10: Run 11: JOG+Run
		Bit 2-3	Not used
		Bit 5,4	00: No function 01: FWD 10: REV 11: Change direction
		Bit 6-15	Not used
	2001H	Freq. command	
	2002H	Bit 0	1: EF (external fault) on
		Bit 1	1: Reset
Bit 2-15		Not used	

Table B-1: Communication Address Definition, continued

Content:	Address:	Function:					
Status monitor Read-only	2100H	Error code: 0: No errors occurred 1: Over-current (oc) 2: Over-voltage (ov) 3: Overheat (oH) 4: Overload (oL) 5: Overload1 (oL1) 6: External fault (EF) 7: Reserved 8: Reserved 9: Current exceeds 2 times rated current during acc. (ocA) 10: Current exceeds 2 times rated current during dec. (ocd) 11: Current exceeds 2 times rated current during steady state operation (ocn) 12: Reserved 13: Reserved 14: Low voltage (Lv) 15: CPU failure 1 (cF1) 16: CPU failure 2 (cF2) 17: b.b. 18: Overload (oL2) 19: Auto acc/dec failure (cFA) 20: Software protection enabled (codE) 21: Reserved 22: CPU failure (cF3.1) 23: CPU failure (cF3.2) 24: CPU failure (cF3.3) 25: CPU failure (cF3.4) 26: CPU failure (cF3.5) 27: CPU failure (cF3.6) 28: CPU failure (cF3.7) 29: Hardware protection failure (HPF.1) 30: Hardware protection failure (HPF.2) 31: Hardware protection failure (HPF.3)					
	2101H	Status of AMD <table border="1"> <tr> <td>Bit 1,0</td> <td>00: RUN LED light off, STOP LED light up 01: RUN LED blink, STOP LED light up 10: RUN LED light up, STOP LED blink 11: RUN LED light up, STOP LED light off</td> </tr> <tr> <td>Bit 2</td> <td>1: JOG active</td> </tr> <tr> <td>Bit 4,3</td> <td>00: REV LED light off, FWD LED light up 01: REV LED blink, FWD LED light up 10: REV LED light up, FWD LED blink 11: REV LED light up, FWD LED light off</td> </tr> </table>	Bit 1,0	00: RUN LED light off, STOP LED light up 01: RUN LED blink, STOP LED light up 10: RUN LED light up, STOP LED blink 11: RUN LED light up, STOP LED light off	Bit 2	1: JOG active	Bit 4,3
Bit 1,0	00: RUN LED light off, STOP LED light up 01: RUN LED blink, STOP LED light up 10: RUN LED light up, STOP LED blink 11: RUN LED light up, STOP LED light off						
Bit 2	1: JOG active						
Bit 4,3	00: REV LED light off, FWD LED light up 01: REV LED blink, FWD LED light up 10: REV LED light up, FWD LED blink 11: REV LED light up, FWD LED light off						

February 2006

Table B-1: Communication Address Definition, continued

Content:	Address:	Function:	
(Reserved)	2101H, continued	Bit 5	Not used
		Bit 5-7	Not used
		Bit 8	1: Main freq. controlled by communication
		Bit 9	1: Main freq. controlled by external terminal
		Bit 10	1: Operation command controlled by communication
		Bit 11	1: Parameters been locked
		Bit 12-15	Not used
	2102H	Frequency command. (FXXX.XX)	
	2103H	Output frequency. (HXXX.XX)	
	2104H	Output current. (AXX.X)	
	2105H	DC-BUS voltage. (UXXX)	
	2106H	Output voltage. (EXXX)	
	2107H	Step number of multi-step speed operation.	
	2108H	Step number of PLC operation.	
	2109H	Time of PLC operation.	
210AH	Value of the counter.		

Company Information

Eaton's electrical business is a global leader in electrical control, power distribution, and industrial automation products and services. Through advanced product development, world-class manufacturing methods, and global engineering services and support, Eaton's electrical business provides customer-driven solutions under brand names such as Cutler-Hammer®, Powerware®, Durant®, Heinemann®, Holec® and MEM®, which globally serve the changing needs of the industrial, utility, light commercial, residential, and OEM markets. For more information, visit www.EatonElectrical.com.

Eaton Corporation is a diversified industrial manufacturer with 2005 sales of \$11.1 billion. Eaton is a global leader in electrical systems and components for power quality, distribution and control; fluid power systems and services for industrial, mobile and aircraft equipment; intelligent truck drivetrain systems for safety and fuel economy; and automotive engine air management systems, powertrain solutions and specialty controls for performance, fuel economy and safety. Eaton has 59,000 employees and sells products to customers in more than 125 countries. For more information, visit www.eaton.com.

Eaton Electrical Inc.
1000 Cherrington Parkway
Moon Township, PA 15108-4312
USA
tel: 1-800-525-2000
www.EatonElectrical.com

EAT•N

Cutler-Hammer

© 2006 Eaton Corporation
All Rights Reserved
Publication No. MN04002003E/CPG
February 2006