

MCH Series Drive/Bypass Package 2 - 250 Hp



DESCRIPTION

The MCH Series variable frequency drive has been specifically designed for HVAC loads such as fans, pumps and cooling towers. The application specific keypad offers easy operation. Features especially useful for fan or pump applications include:

- HOA keys to mimic traditional Hand, Off, and Auto functions
- PID set point control
- Hour and kWh meters
- 32 character plain English backlit LCD display with adjustable viewing angle

The MCH Series is available with an optional Bypass feature that allows the motor to be operated “across-the-line” for critical applications where a redundant means of motor operation is required. This option is factory assembled and wired in a NEMA 1 enclosure. The 3-contactor design allows the drive to be removed if required for service, while the bypass is left in place to operate the motor.

Refer to data sheet #DS-MH for more information on the basic MCH drive.

GENERAL MCH/BYPASS PACKAGE FEATURES

DESIGN FEATURES

- 32 character, plain English, backlit LCD display with adjustable contrast
- Keypad with HOA functionality
- Speed reference sources:
 - 0-10 VDC (scalable)
 - 4-20 mA (scalable)
 - speed pot (scalable)
 - preset speeds (4 available)
 - keypad
- Loss of follower: fault or go to preset speed
- Analog outputs: two available
 - 0-10 VDC or 2-10 VDC (scalable)
 - proportional to speed and load
- Digital outputs:
 - two Form C relays (option for 3rd relay)
- PID setpoint control
- RS-485 serial comm. (Modbus RTU)
- Password protection of parameters
- Surface mount technology
- UL, cUL, and CSA listed

SERVICE CONDITIONS

- Enclosure: NEMA Type 1
- Storage Temperature: -20°C to 70°C
- Ambient Operating Temp: -10°C to 40°C
- Ambient Humidity: Up to 95% (non-condensing)
- Altitude: 3300 ft/1000 m above sea level (higher with derating)

PERFORMANCE FEATURES

- Ratings:
 - 1 to 60 Hp at 240/200 Vac
 - 1 to 250 Hp at 480/400 Vac
 - 1 to 60 Hp at 590/480 Vac
- Accel time: 0.1 to 3600 seconds
- Decel time: 0.1 to 3600 seconds
- Current limit: adjustable up to 120%
- Carrier frequency: 2.5 kHz to 14 kHz
- Sleep Mode with adjustable threshold and time
- Adjustable Volts/Hz ratio
- DC injection braking: adjustable voltage and time
- Skip frequencies: two available with adjustable bandwidth (up to 10 Hz)
- Output frequency: 0-120 Hz
- Analog input filter: adjustable
- Start options:
 - Start upon application of power
 - Auto restart after fault (5 attempts)
 - Flying restart to catch a spinning motor
- 500 ms power loss ride-through

DRIVE OPTIONS

- Door interlocked disconnect switch or circuit breaker
- Input line reactor (std on some models)
- Popular protocols such as MetaSys, LONWorks, BACnet, and Siemens P1
- NEMA 12 enclosures

PROTECTIVE FEATURES

- 120% overload capacity for 60 seconds
- Overvoltage & undervoltage faults
- Output short circuit fault
- Phase to ground fault
- Phase to phase fault
- Electronic thermal overload
- Current limit: adjustable up to 120%
- Overtemperature fault
- External fault input for safety interlocks

ELECTRICAL SPECIFICATIONS

- Input voltage ratings: 240/200 Vac, 480/400 Vac, 590/480 Vac
- Input voltage tolerance: +10%, -15%
- Input frequency tolerance: 48 to 62 Hz
- Input phase sequence insensitive
- Output frequency: 0-120 Hz
- Output wave form: Sine-coded PWM
- Efficiency: > 97% over speed range
- Power factor (displacement): > 0.96

AC Tech

member of the **Lenze** Group

Drive for Global Excellence

DS-MHBP-OHOF

MCH Series Drive/Bypass Package

Bypass Features and Power Schematic

BYPASS STANDARD FEATURES

- All customer wiring terminates in bypass compartment; no need to access drive compartment
- 3 contactors: drive input, drive output, and bypass
- Drive input fuses
- Class 10 thermal overload relay
- Selector switches:
 - Hand / Off / Auto
 - Drive Mode / Off / Bypass Mode
 - Drive Normal / Off / Drive Test
- Pilot lights (red neon):
 - Power On
 - Drive Mode
 - Bypass Mode
 - Safety Circuit Fault
- Two programmable Form C relays
- 120 Vac control transformer (fused primary)
- Terminals for customer use:
 - Safety interlocks
 - Smoke purge



MCH Drive equipped with Bypass, Line Reactor, Disconnect, and Bypass Fuses

BYPASS OPTIONS

- Door interlocked disconnect switch or circuit breaker
- Bypass fuses
- 3rd programmable Form C relay
- 24 VDC, 100 mA power supply for customer use
- Automatic transfer to bypass

What is the Bypass and how does it work?

The Bypass option allows the motor to be operated across line power in the event that the drive is unavailable, or if continued operation at full speed is required. The AC Tech Bypass consists of three contactors. In Drive mode, the VFD input and output contactors are closed, and the Bypass contactor is open. In Bypass mode, the VFD input and output contactors open to fully isolate the drive, while the Bypass contactor closes to apply line power directly to the motor. Control logic is provided to insure proper sequencing of the contactors. Refer to the diagram to the right.

The AC Tech Bypass also has a Drive Test mode, which closes the VFD input contactor (the output contactor remains open), allowing the drive to be configured and programmed while the motor is running in Bypass.

Why are three contactors better than two?

Some drive suppliers only use two contactors in their bypass for a cheaper design. They do not utilize a VFD input contactor, which means that even in Bypass mode, power is still applied to the drive. If a short circuit were to occur in the drive portion of the unit, attempting to apply main power would result in clearing input fuses or tripping the input breaker. This renders the bypass useless, which means the motor cannot be operated (thus defeating the purpose of the bypass). By having the third contactor to completely isolate the drive, the AC Tech bypass will still operate, insuring critical equipment remains on line.

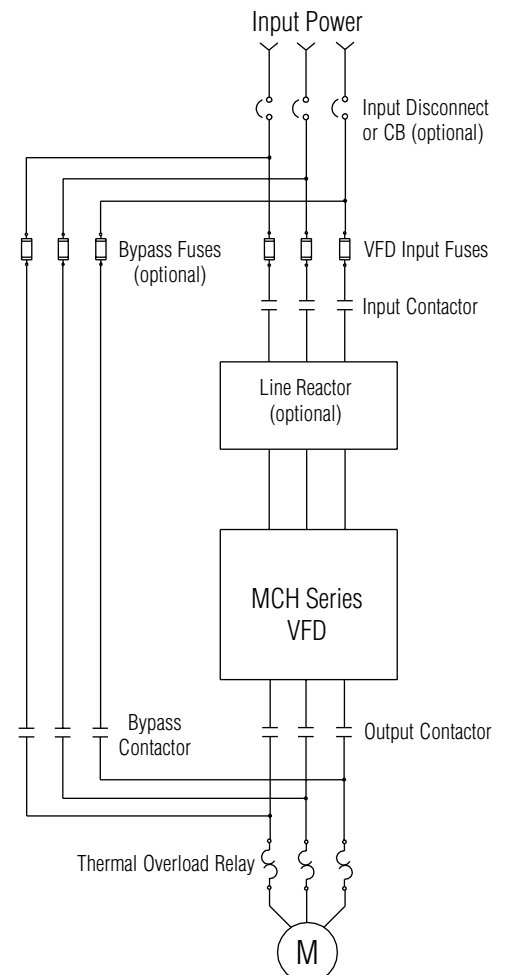

MCH Series Drive/Bypass Package Dimensions

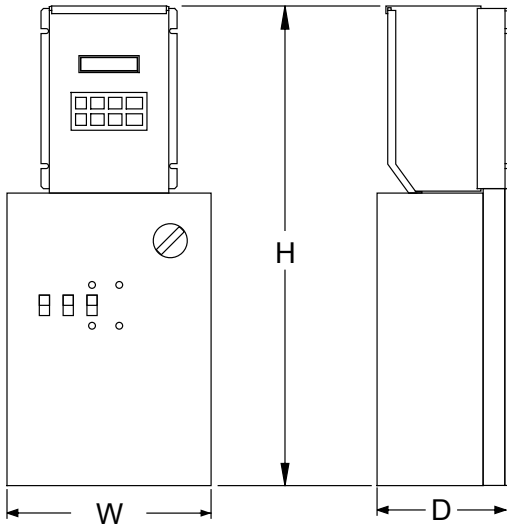

HP	INPUT VOLTAGE	OUTPUT CURRENT	MODEL NUMBER	NEMA 1 DIMENSIONS		
				H	W	D
2	240 / 200	6.8	MH220BG	25.2	11.8	8.3
	480 / 400	3.4	MH420BG	25.2	11.8	8.3
	590 / 480	2.7	MH520BG	25.2	11.8	8.3
3	240 / 200	9.6	MH230BG	25.2	11.8	8.3
	480 / 400	4.8	MH430BG	25.2	11.8	8.3
	590 / 480	3.9	MH530BG	25.2	11.8	8.3
5	240 / 200	15.2	MH250BG	30.6	13.8	10.0
	480 / 400	7.6	MH450BG	25.2	11.8	8.3
	590 / 480	6.1	MH550BG	30.6	13.8	10.0
7.5	240 / 200	22	MH275BG	32.1	13.8	10.0
	480 / 400	11.0	MH475BG	32.1	13.8	10.0
	590 / 480	9.0	MH575BG	32.1	13.8	10.0
10	240 / 200	28	MH2100BG	34.0	13.8	10.0
	480 / 400	14.0	MH4100BG	32.1	13.8	10.0
	590 / 480	11.0	MH5100BG	32.1	13.8	10.0
15	240 / 200	42	MH2150BG	35.5	13.8	10.0
	480 / 400	21	MH4150BG	34.0	13.8	10.0
	590 / 480	17.0	MH5150BG	35.5	13.8	10.0
20	240 / 200	54	MH2200BG	37.5	16.3	10.8
	480 / 400	27	MH4200BG	35.5	13.8	10.0
	590 / 480	22	MH5200BG	35.5	13.8	10.0
25	240 / 200	68	MH2250BG	48.5	18.3	12.2
	480 / 400	34	MH4250BG	37.5	16.3	10.8
	590 / 480	27	MH5250BG	37.5	16.3	10.8
30	240 / 200	80	MH2300BG	48.5	18.3	12.2
	480 / 400	40	MH4300BG	37.5	16.3	10.8
	590 / 480	32	MH5300BG	37.5	16.3	10.8
40	240 / 200	104	MH2400BG*	55.5	24.3	11.9
	480 / 400	52	MH4400BG	40.5	16.3	10.8
	590 / 480	41	MH5400BG	40.5	16.3	10.8
50	240 / 200	130	MH2500BG*	55.5	24.3	11.9
	480 / 400	65	MH4500BG	52.5	18.3	12.2
	590 / 480	52	MH5500BG	52.5	18.3	12.2
60	240 / 200	154	MH2600BG*	69.5	36.3	13.2
	480 / 400	77	MH4600BG	52.5	18.3	12.2
	590 / 480	62	MH5600BG	52.5	18.3	12.2
75	480 / 400	96	MH4750BG*	59.5	24.3	11.9
100	480 / 400	124	MH41000BG*	59.5	24.3	11.9
125	480 / 400	156	MH41250BG*	69.5	36.3	13.2
150	480 / 400	180	MH41500BG*	69.5	36.3	13.2
200	480 / 400	240	MH42000BG*	80.0	50.0	15.2
250	480 / 400	300	MH42500BG*	80.0	50.0	15.2

* Input line reactor is standard.