



M DRIVE® AccuStep 34ac

Technology leading all-in-one brushless step motors with integrated revolutionary new control technology that prevents loss of synchronization due to transient or continued overload, extreme acceleration or deceleration, or excessive slew speed.

MDrive® AccuStep™ motion systems react quickly to large changes in loads without loss of synchronization, delivering the performance of brush, brushless and servo motors in a lower cost solution. Additional benefits include:

- No tuning;
- Higher inertia mismatch allowed;
- High starting torque;
- Smooth motion, even at extremely slow speeds.

The product's enhanced performance is accomplished using a cost effective step motor, while eliminating associated disadvantages. AccuStep control technology benefits include:

- Eliminating loss of synchronization;
- Allowing full use of motor's torque;
- Maintaining constant motor torque *with torque mode*;
- Reduced motor heating *with variable current control*;
- Minimizes impact of system resonance.

MDrive AccuStep motion systems allow a motor to handle large fluctuations in loads even at high rates of change. An available Torque Mode controls rotary and linear applications with specific torque, or force, specifications for use in applications such as web tension control, container capping, and clamping and holding.

Two MDrive AccuStep product versions are available:

Step • Torque • Speed – AccuStep integrated with step motor, microstepping driver and internal encoder. Step, torque and speed operating modes.

Motion Control – AccuStep integrated with motion controller, step motor, microstepping driver and internal encoder. Fully programmable product.

MDrive AccuStep 34ac products feature a NEMA 34 1.8° brushless step motor, microstepping driver, 120VAC or 240VAC integrated power supply, and rugged encoder with index mark that is internal to the unit so length is not increased. Products are built for IP65 rating with a choice of 3 motor lengths. Options include a planetary gearbox, or a rear control knob which nullifies the product's IP65 rating.

Communication is over RS-422/485*, with a USB to RS-422/485 Communications Converter available for ease of connecting to a user's PC. Connectivity options range from all-inclusive QuickStart Kits to individual interfacing cables and mating connector kits to build your own cables. *See pg 7.*

The MDrive AccuStep 34ac accepts a broad input voltage range from 95 to 264 VAC, delivering enhanced performance and speed. The product's all-in-one design eliminates the need to run motor cabling through a machine, reducing the potential for problems due to electrical noise.

Oversized input capacitors are used to minimize power line surges, reducing problems that can occur with long runs and multiple drive systems. An extended operating range of -40° to +75°C provides long life, trouble free service in demanding environments.

With AccuStep control technology, there is now a low cost alternative where brushless technology is required. When you combine its flexible operating environment and long list of features, the integrated motor technology of MDrive AccuStep offers clear advantages in a very cost effective package for a large range of motion control applications.

*CANopen option for Motion Control versions. Inquire for availability.

AccuStep™

AccuStep is a revolutionary control technology that, when applied to step motors, prevents the loss of synchronization due to transient or continued overload, extreme acceleration or deceleration, or excessive slew speed.

AccuStep control technology continually monitors the relationship between the rotor and stator at sub-microsecond intervals, and will not allow that relationship to exceed the point where synchronization is lost.

Variable current control can be enabled to allow only the required current necessary to perform the task, further enhancing performance and efficiency.

Speed-torque performance

AccuStep revolutionary control technology allows full use of a step motor's maximum torque rating;

eliminates derating of up to 50%

as buffer against stalling of standard step motor systems.

Step motor max torque rating
AccuStep control technology motor performance range with Variable Current Control

Standard step motor performance range
(Design margin = 50% maximum torque as buffer against stalling)

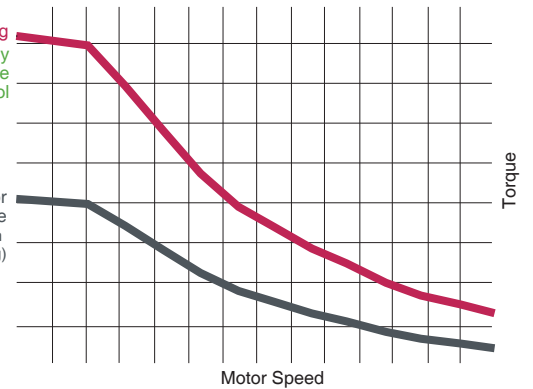

120VAC motor speed-torque curves

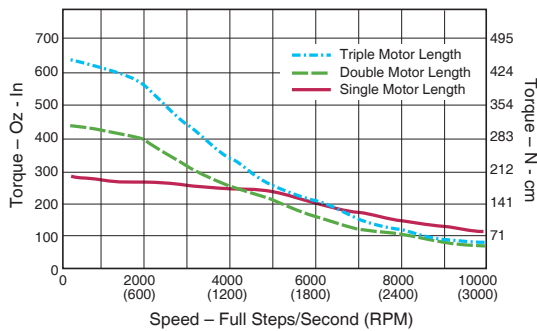

240VAC motor speed-torque curves

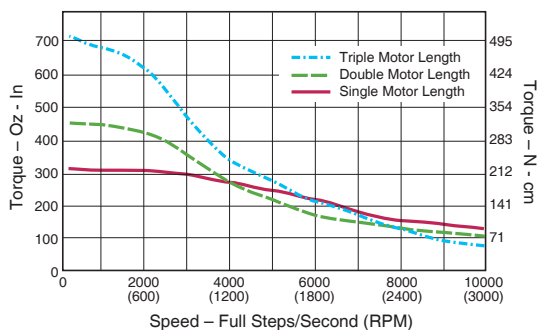

MDrive AccuStep 34ac

MDrive AccuStep motion systems offer clear advantages in a very cost effective package for a wide range of motion control applications such as:

- Point-to-point positioning
 - Reduce motor frame size requirement
- Conveyor control
 - No loss of synchronization
 - Adapts to sudden load changes
- Drilling
 - Variable torque
- Web handling
 - Tension control
- Hydraulic and pneumatics replacement
 - Low cost
 - Accurate and variable positioning
- Rotary and linear positioning to torque specification
 - Container capping
 - Clamping / holding
 - Screw tightening
- On-the-fly product marking (labeling)
 - High acceleration and deceleration rates

Motor specifications

	Holding torque	Detent torque	Rotor inertia	Weight (motor+driver)
Single length	330 oz-in / 233 N-cm	10.9 oz-in / 7.7 N-cm	0.0142 oz-in-sec ² / 1.0 kg-cm ²	6.4 lb / 2.9 kg
Double length	500 oz-in / 353 N-cm	14.16 oz-in / 10.0 N-cm	0.0227 oz-in-sec ² / 1.6 kg-cm ²	7.7 lb / 3.5 kg
Triple length	750 oz-in / 529 N-cm	19.83 oz-in / 14.0 N-cm	0.0482 oz-in-sec ² / 3.4 kg-cm ²	11.0 lb / 5.0 kg

General specifications: all versions

Input voltage (+V)	Range	120 Volt version – 95 to 132 VAC @ 50/60 Hz 240 Volt version – 95 to 264 VAC @ 50/60 Hz	
	Type	RS-422/485	
Communication	Baud rate	4.8 to 115.2kbps	
	Operating temperature	Heat sink	–40° to +75°C (non-condensing)
Motor		–40° to +90°C (non-condensing)	
Protection	Type	Thermal, internal fuse	Designed for line-neutral systems

MDrive AccuStep 34ac Step • Torque • Speed

AccuStep technology integrated with step motor, microstepping driver, velocity generator and encoder. This version operates in three modes:

- Step Mode** operates in typical step and direction input mode for point-to-point positioning.
- Torque Mode** operates in relation to an analog input for positioning to torque setting.
- Velocity Mode** operates as an independent velocity control device, no external controller required.

Standard specifications

Isolated input	Voltage range	+5 to +24 VDC sourcing or sinking		
	Digital filter range	50 nS to 12.9 μS (10 MHz to 38.8 kHz)		
Motion	Clock types (Step mode)	Step/Direction, Quadrature, Step Up/Step Down		
	Step frequency	5 MHz maximum		
		100 ns minimum pulse width		
	Closed loop configuration	Internal optical encoder	Resolutions 100, 200, 250, 256, 400, 500, 512, 1000	
		Number of settings	20	
	Microstep resolution	Steps per revolution	Binary	200, 400, 800, 1600, 3200, 6400, 12800, 25600, 51200, 36000 (0.01 deg/μstep), 21600 (1 arc minute/μstep), 25400 (0.001mm/μstep)
Decimal			1000, 2000, 5000, 10000, 20000, 25000, 40000, 50000	

Setup parameters

An AccuStep configuration GUI is provided for ease of setup and configuring your device. The image (right) depicts the GUI's main screen with choice of operating mode, primary and secondary parameter settings.

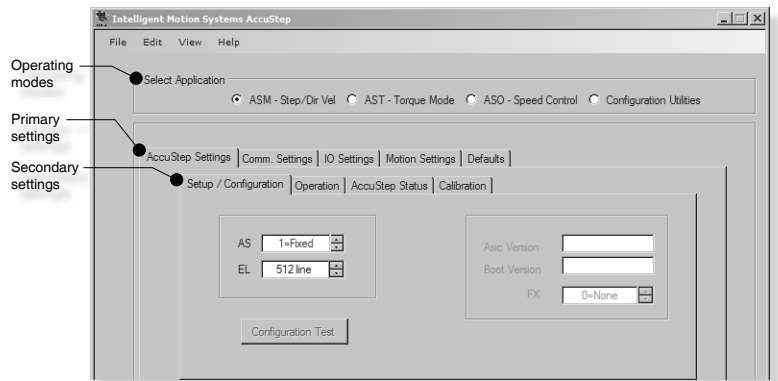

Note that available settings vary with each one of the three operating modes. Shown below is an overview of all settings with general descriptions. More detailed information is covered in the product manual.

Operating Mode (Select Application)	Select: Step & Direction (ASM), Torque Control (AST) or Speed Control (ASO)	
AccuStep Settings	Setup/Configuration	Turn AccuStep off or on in fixed or variable mode; set and confirm encoder line count
	Operation	Set control bounds for motor torque and speed, lead, lag, and make-up of lost steps
	AccuStep Status	Display status alerts of 8 pre-programmed fields, read-only
	Calibration	To maintain synchronization, select options for motor's rotor-to-stator physical position
Analog Settings	Set analog ranges, select input mode: 0-5V, 0-10V, -10 to +10V (not applicable for Step mode)	
Communication Settings	Set baud rate; enable/disable party mode and features; Check Sum integrity quality assurance	
I/O Settings	Clock and filter settings; Attention Output with 11 pre-programmed fields to select among	
Motion Settings	All operating modes	Set various motion settings, which vary with the operating mode selected ex. Current, MSEL
	Speed control mode	Additional settings: for setting acceleration, deceleration, velocity and flags
Defaults	Restore system defaults or previously stored settings; view current communication settings	

Interface pin assignments

P1 I/O connector			
M23 circular (male)	Function	M23 circular (male)	Function
Pin 1	Optocoupler reference	Pin 11	Logic ground
Pin 2	Enable input	Pin 12	no connect
Pin 3	Index +	Pin 13	CW/CCW direction input
Pin 4	Channel B +	Pin 14	Index -
Pin 5	Channel B -	Pin 15	Channel A -
Pin 6	no connect	Pin 16	Analog input
Pin 7	Channel A +	Pin 17	Attention output emitter
Pin 8	Attention output collector	Pin 18	Motion
Pin 9	Aux-Power	Pin 19	Aux-ground
Pin 10	+5VDC output		

P2 Communication connector	
M12 circular (female)	Function
Pin 1	TX -
Pin 2	TX +
Pin 3	RX +
Pin 4	RX -
Pin 5	Communication ground

P3 Power connector	
Euro AC (male)	Function
Pin 1	Chassis ground
Pin 2	AC power line
Pin 3	AC power neutral

MDrive AccuStep 34ac Motion Control

AccuStep technology integrated with step motor, microstepping driver, fully programmable motion controller and encoder. Point-to-point positioning, torque mode and velocity control are all user programmed with the feature rich MCode software and easy-to-use terminal emulator programs provided.

Standard specifications

Aux. logic input voltage	Range	+12 to +24 VDC <i>Maintains power to control and feedback circuits (only) when input voltage is removed.</i>		
	Resolution	10 Bit		
Analog input	Range	0 to +5 VDC, 0 to +10 VDC, 0-20 mA, 4-20 mA		
	Number/type	8 sourcing or sinking outputs/inputs		
General purpose I/O	Logic range	+5 to +24VDC – inputs and sinking outputs; inputs TTL level compatible +12 to +24VDC – sourcing outputs		
	Output sink/source current	Up to 600 mA per channel		
	Protection	Over Temp, Short Circuit, Transient Over Voltage, Over Voltage, Inductive Clamp		
Motion	Closed loop configuration with encoder	Encoder type	Internal, magnetic	
		Steps per revolution	51200	
		Resolution	1000 lines / 4000 edges per rev	
	Counters	Type	Position, encoder	
		Resolution	32 bit	
		Edge rate (maximum)	5 MHz	
	Velocity	Range	+/- 5,000,000 steps per second	
		Resolution	0.5961 steps per second	
	Accel/Decel	Range	1.5 x 10 ⁹ steps per second ²	
		Resolution	90.9 steps per second ²	
High speed I/O	Position capture	Input filter range	50 nS to 12.9 μS (10 MHz to 38.8 kHz)	
		Resolution	32 bit	
	Trip output – speed / resolution / threshold	150 nS / 32 bit / TTL		
Software	Program storage	Type / size	Flash / 6384 bytes	
	User registers	(4) 32 bit		
	User program labels and variables	192		
	Math functions	+, -, x, ÷, >, <, =, <=, >=, AND, OR, XOR, NOT		
	Branch functions	Branch & call		
	General purpose I/O functions	Inputs	Home, Limit Plus, Limit Minus, Go, Stop, Pause, Jog Plus, Jog Minus, General Purpose	
		Outputs	Moving, Fault, Stall, Velocity Change, General Purpose	
	Trip functions	Trip on Input, Trip on Position, Trip on Time, Trip Capture, Trip on Relative Position		
	Party mode addresses	62		
Encoder functions	Stall Detection, Position Maintenance, Find Index			

Programming

The MDrive AccuStep Motion Control version is fully programmable. Users can quickly communicate and program via a PC using IMS Terminal, an integrated ASCII terminal emulator and program editor available for download at www.imshome.com.

Interface pin assignments

P1 I/O connector			
M23 circular (male)	Function	M23 circular (male)	Function
Pin 1	I/O 9	Pin 11	I/O power
Pin 2	I/O 11	Pin 12	no connect
Pin 3	no connect	Pin 13	I/O 12
Pin 4	I/O 1	Pin 14	Capture/Trip I/O
Pin 5	no connect	Pin 15	Analog in
Pin 6	no connect	Pin 16	I/O 2
Pin 7	Aux power	Pin 17	I/O 4
Pin 8	Aux ground	Pin 18	I/O 10
Pin 9	I/O 3		
Pin 10	I/O ground	Pin 19	no connect

P2 Communication connector	
M12 circular (female)	Function
Pin 1	TX –
Pin 2	TX +
Pin 3	RX +
Pin 4	RX –
Pin 5	Communication ground

P3 Power connector	
Euro AC (male)	Function
Pin 1	Chassis ground
Pin 2	AC power line
Pin 3	AC power neutral

Mechanical specifications

Dimensions in Inches (mm)

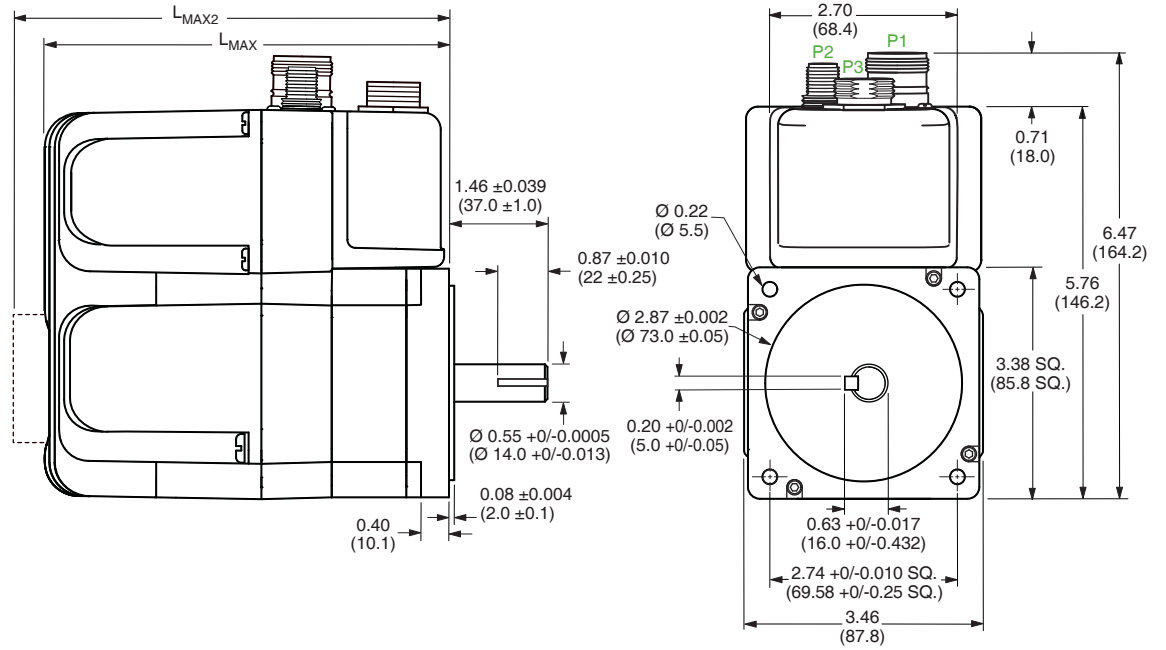

MDrive AccuStep lengths Inches (mm)

Motor length	LMAX	LMAX2
	with single shaft or internal encoder	with control knob
Single	6.1 (155.0)	7.1 (180.4)
Double	6.9 (174.3)	7.9 (199.7)
Triple	8.4 (214.3)	9.4 (239.7)

L_{MAX2} option

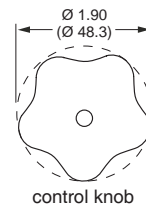

connectors

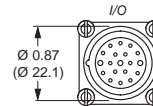

P1: 19-pin M23

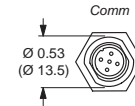

P2: 5-pin M12

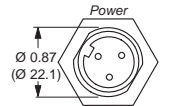

P3: 3-pin Euro AC

Order information

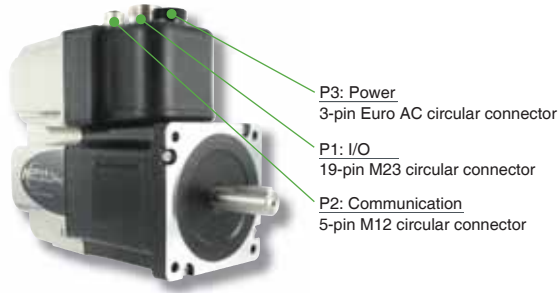

Connectivity

QuickStart Kit

For rapid design verification, all-inclusive QuickStart Kits have communication converter, prototype development cables, instructions and CD for MDrive AccuStep initial functional setup and system testing.

Communication Converter

Electrically isolated, in-line converter pre-wired with mating connector to conveniently set/program parameters for a single MDrive AccuStep via a PC's USB port. Length 12.0' (3.6m).

Mates to:

P2 connectorMD-CC401-001

Prototype Development Cables

Speed test/development with pre-wired mating connectors that have flying leads opposite end. Single-ended cordsets are PVC jacketed with foil shield and unconnected drain wire. Length 13.0' (4.0m).

Mates to:

P1 connector
 with straight terminationMD-CS100-000
 with right angle terminationMD-CS101-000
 P3 connector
 with straight terminationMD-CS200-000
 with right angle terminationMD-CS201-000

Options

Control Knob

MDrive AccuStep is available with a factory-mounted rear control knob for manual shaft positioning.

Planetary Gearbox

Efficient, low maintenance planetary gearboxes are offered assembled with the MDrive AccuStep. Refer to details and part numbers on the back cover.

Encoder

Step•Torque•Speed Versions

An internal differential optical encoder with index mark is included with signals made available for external use. Resolutions from 100 to 1000 lines are available.

Motion Control Versions

A 1000 line internal differential magnetic encoder with index mark is included for requisite closed loop configuration.

NOTE: AccuStep control performance is optimized at the higher resolution selections.

Part numbering

Step • Torque • Speed version

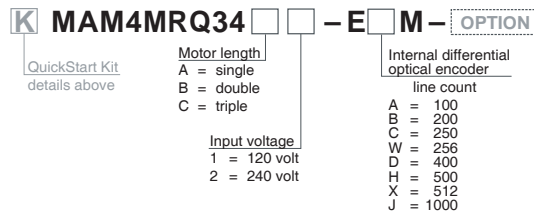

Motion Control version

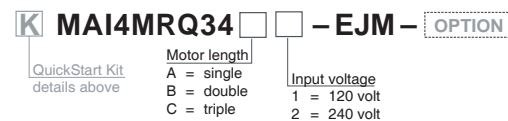

Options

Control Knob

-N

Ex: **MAI4MRQ34A1-EJM-N** adds a rear control knob for manual positioning to example part number. Not IP65.

Planetary Gearbox

-G - **F**

Optional NEMA Flange

Refer to gearbox page for complete table of ratios and part numbers.
 Ex: **MAI4MRQ34A1-EJM-G1A2** adds 1-stage planetary gearbox with 5.18:1 ratio to example part number. Add -F for optional NEMA flange. Not IP65.

Example part number: **MAI4MRQ34A1-EJM** is an MDrive AccuStep 34ac Motion Control with industrial circular connectors, RS-422/485 communication, NEMA 34 single length motor, and default encoder.

Planetary gearbox

The MDrive AccuStep 34ac is available with a Planetary Gearbox option developed to increase torque at lower speeds, enable better inertia matching and produce finer positional resolutions. These efficient, low maintenance Planetary Gearbox come fully assembled with the MDrive and are offered in a large number of reduction ratios in 1-, 2- and 3-stage configurations. An optional NEMA Output Flange allows mounting the Planetary Gearbox to the load using a standard NEMA bolt circle.

Parameters

	Permitted output torque (oz-in/Nm)	Gearbox efficiency	Maximum backlash	Output side with ball bearing			
				Maximum load (lb-force/N)		Weight (oz/g)	
				Radial	Axial	Gearbox	with Flange
1-stage	2832/20.0	0.80	1.0°	90/400	18/80	64.4/1827	66.7/1890
2-stage	8496/60.0	0.75	1.5°	135/600	27/120	89.5/2538	92.6/2625
3-stage	16992/120.0	0.70	2.0°	225/1000	45/200	114.6/3248	118.5/3360

Ratios and part numbers

Planetary gearbox	Ratio (rounded)	Part number**
1-Stage	3.71:1	G1A1
1-Stage	5.18:1	G1A2
1-Stage	6.75:1	G1A3
2-Stage	13.73:1	G1A4
2-Stage	15.88:1	G1A5
2-Stage	18.37:1	G1A6
2-Stage	19.20:1	G1A7
2-Stage	22.21:1	G1A8
2-Stage	25.01:1	G1A9
2-Stage	26.85:1	G1B1
2-Stage	28.93:1	G1B2
2-Stage	34.98:1	G1B3
2-Stage	45.56:1	G1B4
3-Stage	50.89:1	G1B5
3-Stage	58.86:1	G1B6
3-Stage	68.07:1	G1B7
3-Stage	71.16:1	G1B8
3-Stage	78.72:1	G1B9
3-Stage	92.70:1	G1C1
3-Stage	95.18:1	G1C2
3-Stage	99.51:1	G1C3
3-Stage	107.21:1	G1C4
3-Stage	115.08:1	G1C5
3-Stage	123.98:1	G1C6
3-Stage	129.62:1	G1C7
3-Stage	139.14:1	G1C8
3-Stage	149.90:1	G1C9
3-Stage	168.85:1	G1D1
3-Stage	181.25:1	G1D2
3-Stage	195.27:1	G1D3
3-Stage	236.10:1	G1D4
3-Stage	307.55:1	G1D5

Dimensions in inches (mm)

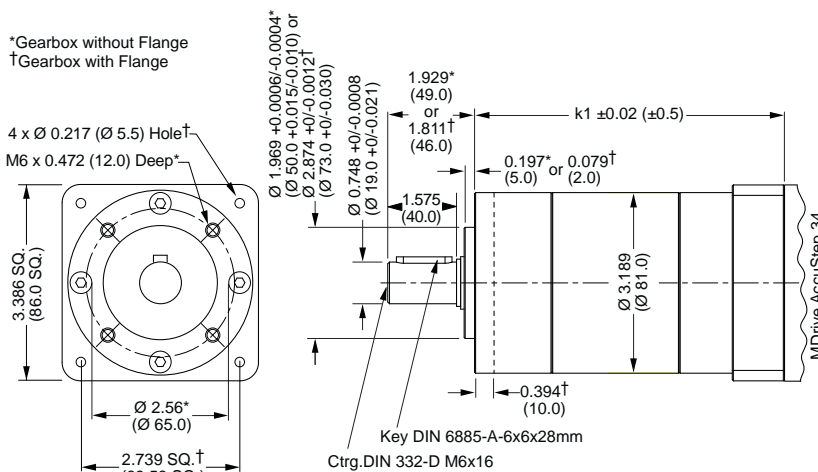

Gearbox lengths in inches (mm)

	k1	
	Gearbox*	with Flange†
1-Stage	4.315 (109.6)	4.433 (112.6)
2-Stage	5.169 (131.3)	5.287 (134.3)
3-Stage	6.024 (153.0)	6.142 (156.0)

**Include optional planetary gearbox by adding -G plus 3 characters to the end of an MDrive AccuStep part number.

U.S.A. SALES OFFICES

Eastern Region

Tel. 862 208-9742 - Fax 973 661-1275
e-mail: e.region@imshome.com

Northeast Region

Tel. 860 368-9703
e-mail: n.region@imshome.com

Central Region

Tel. 860 295-6102
e-mail: c.region@imshome.com

Western Region

Tel. 602 578-7201
e-mail: w.region@imshome.com

TECHNICAL SUPPORT

Tel. +00 (1) 860 295-6102 - Fax +00 (1) 860 295-6107
e-mail: etech@imshome.com

IMS EUROPEAN SALES MANAGEMENT

4 Quai Des Etroits
69005 Lyon, France
Tel. +33/4 7256 5113 - Fax +33/4 7838 1537
e-mail: europe.sales@imshome.com

IMS UK Sales

University of Warwick Science Park, Sir William Lyons Road
UK - CV4 7EZ Coventry, Warwickshire
Tel. +44/0 7796 134462 - Fax +44/0 2476 692047
e-mail: uk.sales@imshome.com

IMS ASIA PACIFIC OFFICE

30 Raffles Pl., 23-00 Chevron House
Singapore 048622
Tel. +65/6233/6846 - Fax +65/6233/5044
e-mail: asia.sales@imshome.com

Intelligent Motion Systems, Inc.

370 North Main Street, P.O. Box 457
Marlborough, CT 06447 - U.S.A.
Tel. +00 (1) 860 295-6102 - Fax +00 (1) 860 295-6107
e-mail: info@imshome.com
http://www.imshome.com

IMS
is becoming

Schneider
Electric

IMS™

INTELLIGENT MOTION
SYSTEMS, INC.